



Owner's Manual

F430

F430

Introduction

The aim of this Owner's Manual is to help you get the best value from your vehicle and to provide information on routine maintenance.

We advise you to read it carefully before setting out. The Owner's Manual is an integral part of the vehicle and it must therefore always be kept on board.

This manual refers to vehicles with two types of transmission:

- F1 electronically-controlled gearbox
- mechanical gearbox

Therefore some information may vary depending on the gearbox installed.

Consulting the manual

To facilitate reading and fast consultation, the topics have been divided into sections and chapters. The important parts requiring particular attention are easily identifiable in the sections and chapters.

 **Extreme caution required: failure to comply with the instructions could cause hazardous situations involving personal and vehicle safety!**

Important note: *warning aimed at preventing any damage to the vehicle and thus hazards involving the safety of persons.*

Abbreviations

Some descriptions and terms with particular meanings are found in this manual in an abbreviated form:

A.C.	AIR CONDITIONING SYSTEM
ABS	ANTI-LOCK BRAKING SYSTEM
ASR	ANTI-SKID REGULATION during acceleration
EBD	ELECTRONIC BRAKE-FORCE DISTRIBUTION
CST	TRACTION STABILITY CONTROL
MSR	Engine braking torque adjustment
ECU	ELECTRONIC CONTROL UNIT
F1	FORMULA 1 - Electronically-controlled gearbox, designed with the same technology as used in the racing sector
L.C.	LAUNCH CONTROL - strategy for performance standing start.

Service

The information contained in this manual is limited to those instructions and indications that are strictly required for the use and good preservation of the vehicle.

Carefully following the instructions contained herein will help you get the best results and satisfaction from your vehicle. We also recommend you have all the checks and service carried out at our Dealers or Authorised Workshops as they have the skilled staff and appropriate equipment available.

See the "Sales and Service Organisation" manual for the locations of the **FERRARI** Dealers and **AUTHORISED SERVICE CENTRES**. The **FERRARI** Technical Service Department is at your complete disposal for any information and suggestions.

Updating

The high quality of your vehicle is guaranteed by constant improvements and there may hence be differences between this manual and your vehicle.

All specifications and illustrations contained in this manual refer to those resulting as of the printing date.

Spare parts

When replacing parts or topping up with lubricants and fluids, we recommend you use original spare parts and the lubricants and fluids recommended by FERRARI.

The FERRARI warranty is voided if ORIGINAL FERRARI SPARE PARTS are not used for repairs.

Chassis

The chassis of this vehicle is entirely constructed of aluminium.

If the chassis is damaged in an accident, have it repaired at the FERRARI SERVICE NETWORK only.

Using non-original spare parts and having inexperienced persons carry out repairs may have serious consequences for the vehicle.

In normal conditions of use the chassis does not require any maintenance; it is however advisable to contact the FERRARI SERVICE NETWORK at the intervals indicated in the Service Time Schedule in order to have it checked.

 Should emergency repairs be required, it is advisable to have the vehicle checked by the FERRARI SERVICE NETWORK as soon as possible.

F1 gearbox

 **Warning:** The vehicle may be fitted with an electro-hydraulically-controlled gearbox system, driven by means of levers on the steering wheel.

Even though the system can be used in "Automatic" mode, it should not be considered an automatic gearbox. Hence, for proper use always follow the instructions given in this manual on page 70.

F430

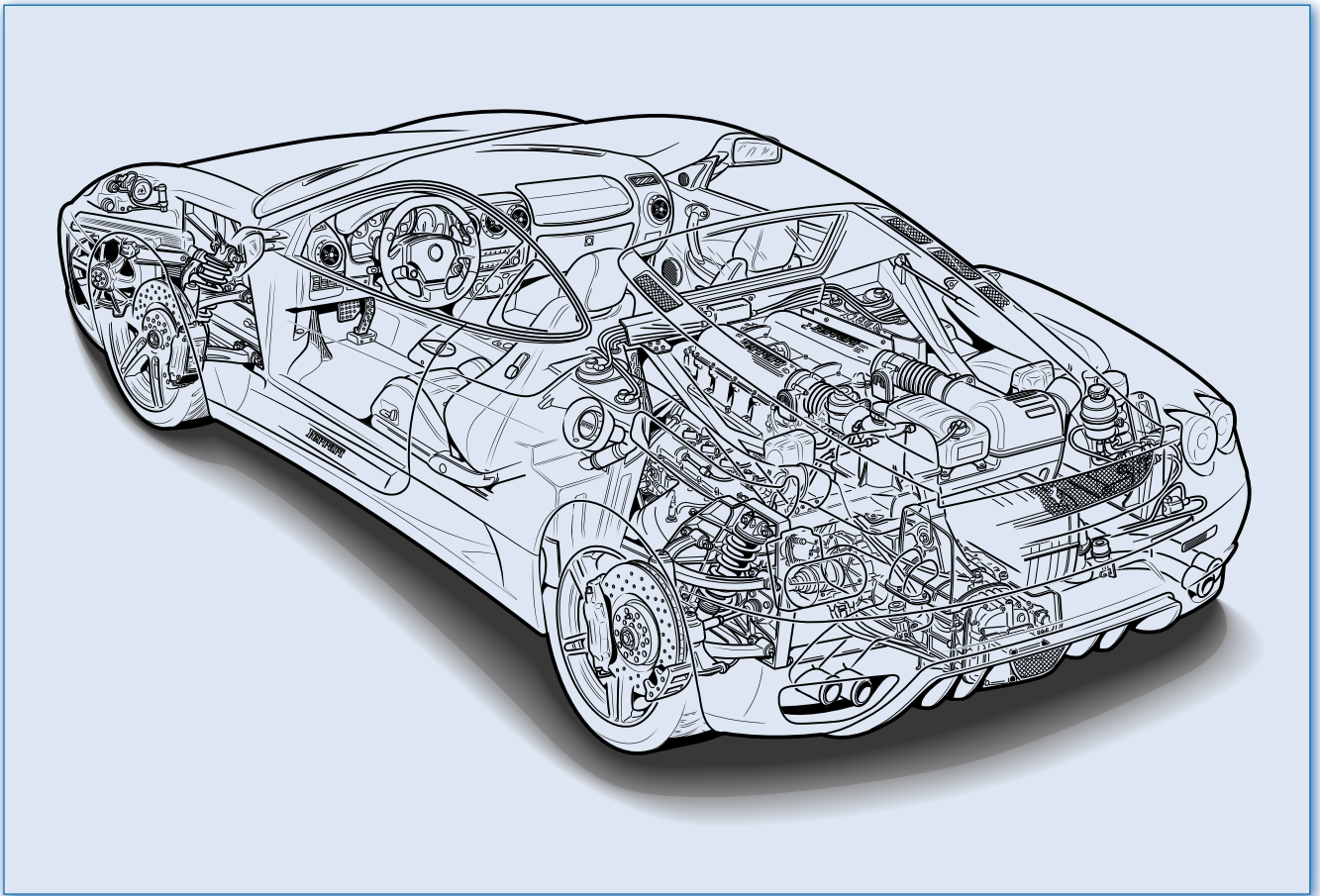

1 - General information

2 - About your vehicle

3 - Driving your vehicle

4 - In an emergency

5 - Maintenance

6 - Technical information

7 - Table of contents

F430

6

1 - General information

Identification and homologation data	8
Instruction plates	9
Main engine specifications	10
Transmission ratios	10
Performance	10
Consumption and CO ₂ emissions	11
Dimensions and weights	11
Rims and tyres	12
Electric system	13
Recommended lubricants and fluids	14



F430

Identification and homologation data

Identification data:

- ① Punched chassis number.

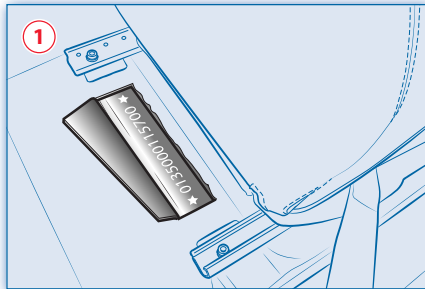

- ② Summary plate with chassis type and number.

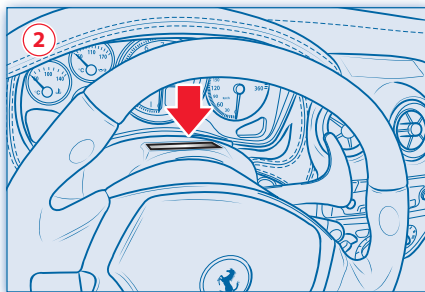

- ③ Punched engine type and number.

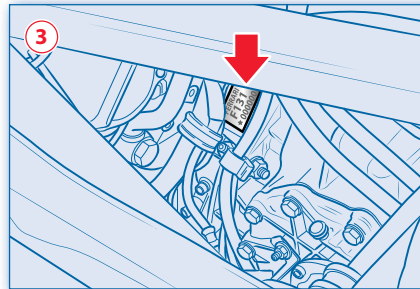

- ④ Assembly number plate.

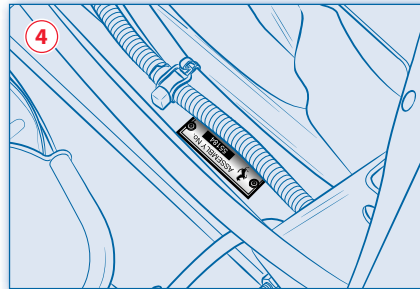

- ⑤ Punched gearbox type and number.

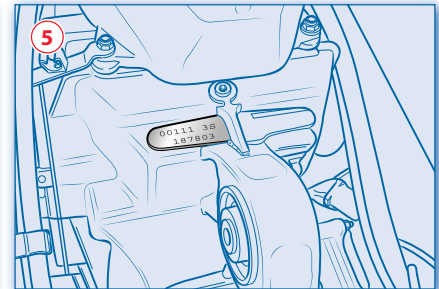

- ⑥ Vehicle identification.

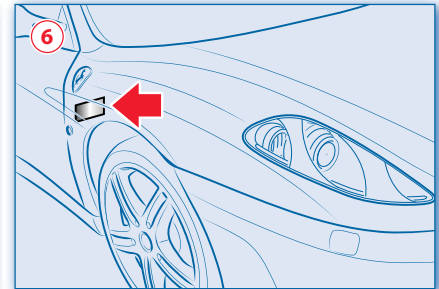

1 - General information

Homologation plates:

⑦ ECE homologation.

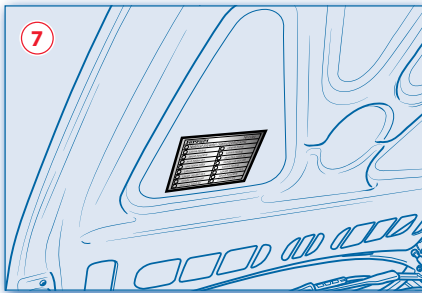

⑧ High beam homologation.

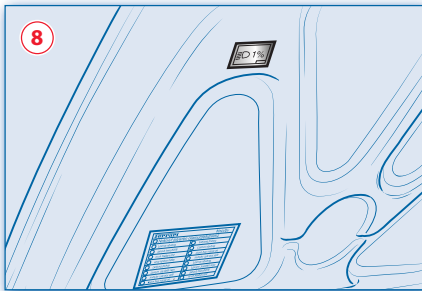

Instruction plates

① Paint code plate.

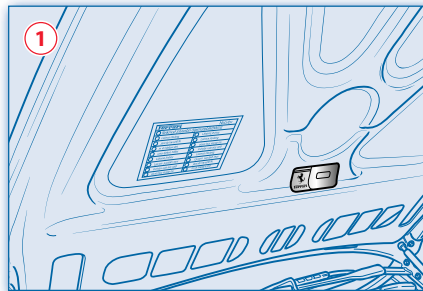

② Lubricants plate.

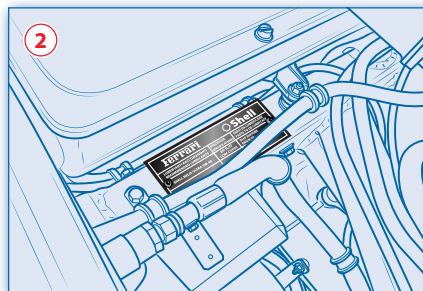

③ Fuel plate.

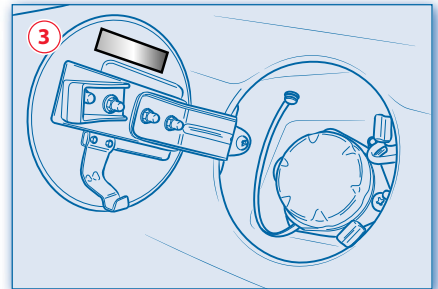

④ Antifreeze plate.

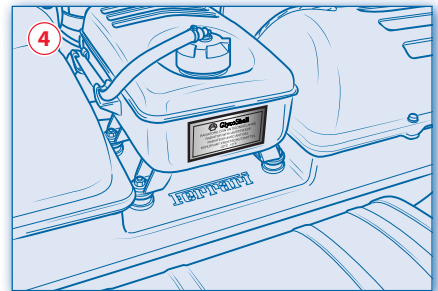

F430

⑤ Tyre pressure plate.

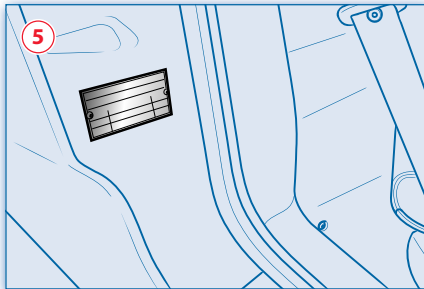

⑥ Battery master switch plate.

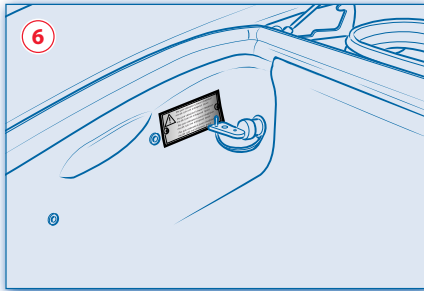

Main engine specifications

Type	F 136 E
Number of cylinders	8 - V 90°
Cylinder bore	mm 92 (3.622 in.)
Piston stroke	mm 81 (3.189 in.)
Total displacement	cm ³ 4308 (262.788 cu.in.)
Compression ratio	11,3 : 1
(*) Max power: (2002/80B/CE)	kW 360,3 (490 HP)
Corresponding r.p.m.	rpm 8500
Maximum torque (2002/80B/CE)	Nm 465
Corresponding r.p.m.	rpm 5250

(*) *A slight boosting is attainable at top speed.*

Transmission ratios

Gear ratios	Differential bevel gear pair ratio	Total transmission ratio (engine/wheel rev)
1 46 / 14 = 3,29	4,30 (10/43)	1 14,13
2 41 / 19 = 2,16		2 9,28
3 37 / 23 = 1,61		3 6,92
4 33 / 26 = 1,27		4 5,46
5 30 / 29 = 1,03		5 4,45
6 31 / 38 = 0,82		6 3,51
R 41 / 15 = 2,73		R 11,75

Performance

	0-100 km/h	0-400 m	0-1000 m	Max. speed.
F1 gearbox	4,0 sec.	11,95 sec	21,60 sec	over 315 km/h (195.74 mph)
Mechanical gearbox	4,0 sec.	12,00 sec	21,65 sec	over 315 km/h (195.74 mph)

1 - General information

Consumption and CO₂ emissions

<i>Dir. 1999/100 EEC</i>	<i>g/km</i>	<i>l/100 km</i>
• Urban cycle	615	26,9
• Extra-urban cycle	305	13,3
• Combined cycle	420	18,3

Dimensions and weights

Wheel base	2600 mm (102.36 in.)
Max. length	4512 mm (177.63 in.)
Max. width	1923 mm (75.70 in.)
Max. height	1214 mm (47.79 in.)
Front track	1669 mm (65.70 in.)
Rear track	1616 mm (63.62 in.)
Kerb weight	1450 Kg (3196.67 lb.)

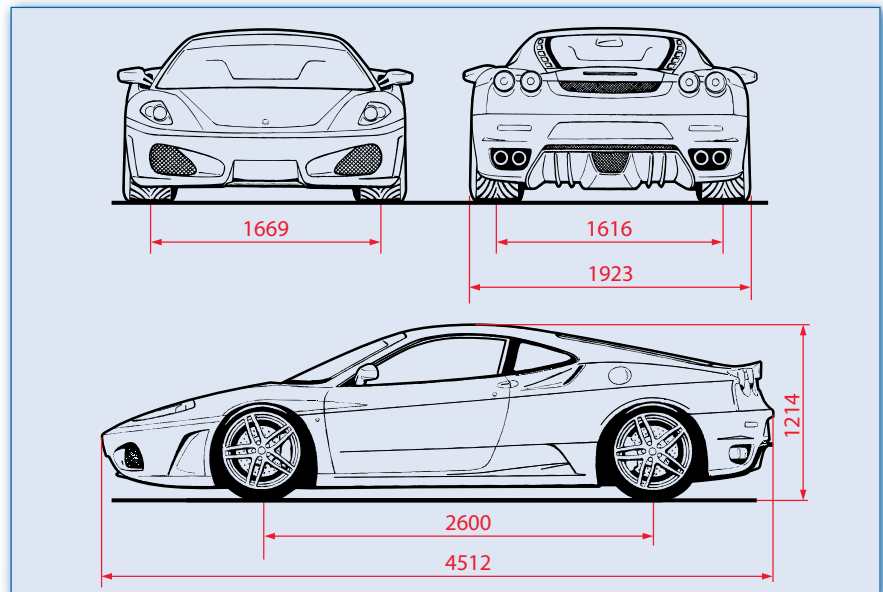

F430

Rims and tyres

Wheel rims

<i>Front</i>	<i>Rear</i>	<i>Spare wheel</i>
7,5" J x 19"	10" J x 19"	3,5" J x 19"

Tyres tested by FERRARI (all tyres without air chamber)

			Inflation pressure (cold)	
	<i>Front</i>	<i>Rear</i>	<i>Front</i>	<i>Rear</i>
Pirelli P Zero Rosso	225/35 ZR19"	285/35 ZR19"	2,2 bar (32,3 psi)	2,2 bar (32,3 psi)
Bridgestone Potenza RE050A	225/35 ZR19"	285/35 ZR19"	2,3 bar (33,8 psi)	2,5 bar (36,7 psi)
Michelin Pilot Sport 2	225/35 ZR19"	285/35 ZR19"	2,2 bar (32,3 psi)	2,4 bar (35,3 psi)

Optional tyres (Run Flat)

Goodyear Regol F1 GS-D3 EMT	225/35 ZR19"	285/35 ZR19"	2,5 bar (36,7 psi)	2,5 bar (36,7 psi)
-----------------------------	--------------	--------------	--------------------	--------------------

Snow tyres (max. speed 210 km/h)

Pirelli Winter Sottozero	225/35 ZR19"	285/35 ZR19"
--------------------------	--------------	--------------

Replacing a wheel



For the correct procedure, see the notes on page 82.

<i>Stud bolt pre-tightening</i>	<i>Stud bolt final tightening</i>
35±40 Nm	100 Nm

Spare wheel

<i>Tyre (max. speed 80 km/h)</i>	<i>Inflation pressure (cold)</i>
Pirelli T 115/70 R19"	4,2 bar (62 psi)

1 - General information

“Run flat” tyres (optional)

The vehicle can be fitted with “Run Flat” tyres. This type of tyre has reinforced sidewalls which permit the vehicle to continue travelling at a moderate speed (80 km/h - 50 mph) for a set distance, even in the event of a puncture.

Always comply with the specified wheel alignment values, as this is fundamental to obtain the best performance from and the longest life of your tyres.

Further information on these tyres and the relevant pressure monitoring system can be found in the “Scaglietti Bodywork” Owner’s manual.

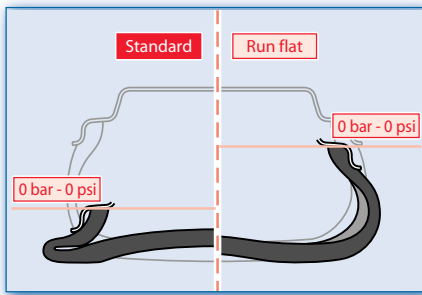

Electric system

Power supply voltage
12 V

Battery
Fiamm ECO FORCE VR760 - 12V - 65 Ah
- 450 A

Alternator
Nippondenso 150 A

Starter motor
Nippondenso







Key-operated circuits

- Starting
- Windscreen wipers and washer
- Stop lights
- Direction indicators
- Hazard lights
- Rear fog lights
- Reverse lights
- Glove compartment light
- Cigarette lighter
- Ignition
- Injection
- Electric fuel pumps
- Air conditioning and heating system
- Instruments
- Water radiator cooling fan motors
- Heated rear window and rear view mirror defroster

- Exterior rear view mirror adjustment
- Shock absorber calibration control system
- CST system
- Exhaust temperature control circuit
- Tyre pressure monitoring system (optional)

F430

Recommended lubricants and fluids

<i>Parts to be refilled</i>	<i>Quantity</i>	<i>Fill with:</i>	<i>Ref. Page</i>
Engine			
Total system capacity	10 l (2.2 Imp.Gall.)	 Shell HELIX ULTRA SAE 5W-40	99-110
Oil quantity between MIN and MAX	1,5 l (0.33 Imp.Gall.)		
Oil consumption (depending on driving conditions)	1,0 ÷ 2,0 l / 1.000 km		
Gearbox and differential (including lines)	3,5 l (0.77 Imp.Gall.)	 Shell TRANSAXLE OIL SAE 75W-90	117
F1 gearbox system - Electronic differential	1,0 l (0.22 Imp.Gall.)	 Shell DONAX TX	99
Brake and clutch system	1,3 l (0.286 Imp.Gall.)	 Shell DONAX UB BRAKE FLUID DOT4 Ultra	100
Cooling circuit • 50:50 mixture of water and coolant	17,5 l (3.85 Imp.Gall.)	GLYCOSHELL	100-111
Hydraulic steering system	1,8 l (0.396 Imp.Gall.)	 Shell DONAX TX	99
Steering box	100 g (0.22 Imp.Gall.)	 Shell RETINAX CS00	
Fuel tank	95,0 l (20.89 Imp.Gall.)	Unleaded fuel 95 N.O.	112
Reserve	20,0 l (4.4 Imp.Gall.)		
Air conditioning and heating system			
Compressor	165 cc (10.065 cu.in.)	DELPHI 7CVC	
Compressor oil	150 cc (9.15 cu.in.)	DELPHI RL897	
Coolant	800 ± 30 g (1.863±0.066 lb.)	"R 134 A"	
Windscreen and headlight washer tank	6,5 l (1.43 Imp.Gall.)	Mixture of water and glass cleaner	103

Note: To clean the windscreen, use one phial of glass-cleaner in summer and two in winter.

2 - About your vehicle

Keys	16
Alarm system	16
Steering wheel controls	21
Instrument panel	29
Warning lights	32
Multi-function display	34
Dashboard controls	36
Controls on the tunnel	43
Doors	46
Seat controls	47
Interior rearview mirror	49
Safety	50
Seat belts	51
Airbag	55
Passenger compartment accessories	57
Internal lights	59
Hands-free microphone (optional)	59
Engine compartment lid	60
Air conditioning and heating system	61



F430

Keys

The vehicle is delivered with two identical keys.

⚠ Write the code number of the key in the space provided in the warranty booklet.

A duplicate of the keys can be requested communicating the identification number to the FERRARI SERVICE NETWORK.

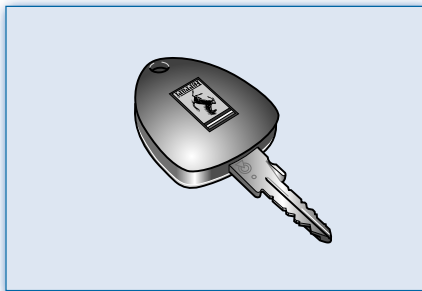

Key codes

A CODE CARD is supplied with the keys. This card indicates the following:

- the electronic code to be used for “emergency starting”;
- the mechanical code for the keys, to be given to the **FERRARI SERVICE NETWORK** in the case that you request duplicates of the keys.

⚠ The code numbers shown on the CODE CARD should be kept in a safe place.

⚠ You are advised to always keep the CODE CARD number with you, as this is absolutely necessary in the event of an “emergency start”.

In the event of a vehicle ownership transfer, it is essential that the new owner is provided with all the keys and with the CODE CARD.

You are advised to record and keep the codes listed on the tags delivered with the keys and the remote control in a safe place (not in the vehicle) in order to request duplicates if needed.

Alarm system

FERRARI CODE system

For greater protection against theft, the vehicle is equipped with an electronic engine immobilizer system (FERRARI CODE), which is automatically activated when the ignition key is removed.

Each ignition key contains an electronic device which transmits a code signal to the FERRARI CODE control unit, and engine ignition is enabled only if the key code is acknowledged by the system.

Two keys are supplied with the vehicle.

The key serves to:

- lock/unlock the doors (central door locking)
- activate/deactivate the passenger airbag (not present in Australian and Japanese versions)
- activate/deactivate the alarm.

Operation

Each time the ignition key is removed from position 0, the protection system activates the engine immobilizer.

- When starting the engine, press the **ENGINE START** button on the steering wheel:

2 - About your vehicle

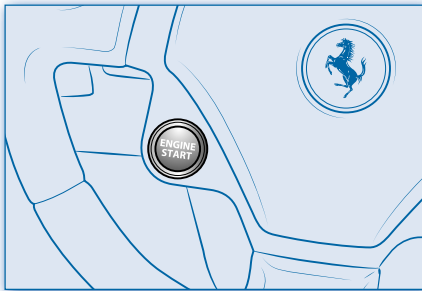

- 1) If the code is recognized, the **CODE** warning light on the instrument panel goes off within a second, while the **EOBD** warning light goes off after about four seconds once the ECU diagnostic cycle has been completed. In these conditions, the protection system recognizes the key code and deactivates the engine immobilizer.

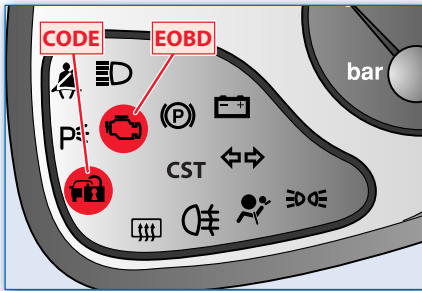

- 2) If the **CODE** warning light stays on and the **EOBD** warning light does not

go off after the four seconds required by the ECU to run a diagnostic cycle, the code has not been recognised. In this case, it is advisable to turn the key back into position 0 then back to **II**. If the immobilizer stays on, try with the other keys. If you are still unable to start the engine, do an emergency start (see the chapter "Emergency starting") and contact the **FERRARI SERVICE NETWORK**.

- When driving with the ignition key in position **II**:
 - 1) If the **CODE** warning light comes on, it means that the system is running a self-diagnostic cycle. At the first stop you can test the system: switch off the engine by turning the ignition key to position 0, then turn it back to position **II**: the **CODE** warning light will come on and should go off within one second. If the warning light stays on, repeat the procedure described previously leaving the key at 0 for more than 30 seconds.

If the problem persists, contact the **FERRARI SERVICE NETWORK**.

- 2) If the **CODE** warning light flashes, it means that the vehicle is not protected by the immobilizer device.

Immediately contact the **FERRARI SERVICE NETWORK** to have all the keys stored in the memory.

Strong impact can damage the electronic components in the key.

Each key supplied has its own specific code, which must be stored in the memory of the system control unit.

Duplicating the keys

When ordering additional keys, remember that the storage procedure (maximum 7 keys) must be carried out for all the keys, including those already in your possession. Directly contact the **FERRARI SERVICE NETWORK**, bringing with you all the keys in your possession, the **CODE CARD** for the **FERRARI CODE** system, a personal ID document and the registration documents proving ownership of the car.

The codes of any keys that are not available when the new storage procedure is carried out will be deleted from the memory to prevent any lost or stolen keys being used to start the vehicle.

Emergency starting

If the **FERRARI CODE** fails to disable the engine immobilizer, the **CODE** warning light comes on fixed and the **EOBD** warning light goes off after four seconds and then comes on again immediately, and the engine will not start. In this condition, the engine can only be started with the emergency starting procedure.

It is recommended to carefully read through the whole procedure before carrying it out.

If you make a mistake, turn the key to position 0 and repeat the operation from step 1.

- 1) Read the 5-digit electronic code found on the CODE CARD.
- 2) Turn the ignition key to position **II**: at this point, the **CODE** and **EOBD** warning lights stay on.
- 3) Push and hold down the accelerator pedal. After approximately 8 seconds, the **EOBD** warning light will go off. Release the accelerator pedal and get ready to count the number of times the **EOBD** warning light flashes.
- 4) Wait until the number of flashes is equal to the first digit of your CODE CARD, then push and hold down the accelerator pedal until the **EOBD** warning light goes off after about 4 seconds, then release the accelerator pedal.
- 5) The **EOBD** warning light starts flashing again. When the number of flashes is equal to the second digit of your CODE CARD, push and hold down the accelerator pedal.
- 6) Proceed in the same manner for the remaining digits in the code on the CODE CARD.
- 7) When the last digit has been entered, hold the accelerator pedal pushed down. The **EOBD** warning light comes on for 4 seconds and then goes off;

release the accelerator pedal.

- 8) When the **EOBD** warning light flashes fast (for about 4 seconds) it confirms that the procedure has been carried out correctly.
- 9) Proceed with starting the engine by pressing the **ENGINE START** button on the steering wheel.

If the **EOBD** warning light remains on, turn the key to position 0 and repeat the procedure from step 1.

This procedure can be repeated an unlimited number of times.

After an emergency start, it is advisable to contact the **FERRARI SERVICE NETWORK** as the emergency starting procedure has to be carried out for each starting.

Electronic alarm system

The electronic alarm system carries out the following functions:

- remote control for central door locking;
- perimeter surveillance, detecting when the doors or lids are opened;
- car movement surveillance.

The engine immobilizer function is guaranteed by the **FERRARI CODE** system, which is automatically activated when the ignition key is removed from the switch.

System activation

Press button **A** on the key to activate the alarm system:

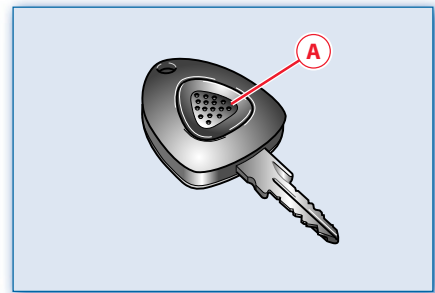

- the direction indicators flash once
- the red LED **B** on the dashboard flashes

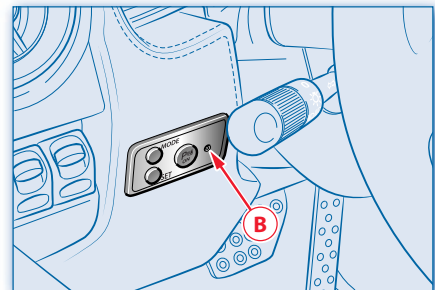

- the central door locking system is activated and the doors are locked.
- After about 25 seconds, the system is active and the alarm will be triggered if:
- a door is opened
 - the luggage compartment lid is opened
 - the engine compartment lid is opened
 - the power is cut

2 - About your vehicle

- the siren is disconnected
- the car is moved.

Should the siren beep twice when you activate the alarm system, this means that one of the doors or the luggage/engine compartment lid is not perfectly closed and therefore is not protected by the perimeter surveillance.

Check that the doors and lids are properly closed and close the open door or lid, then reactivate the alarm system.

Deactivation

Press button **A** on the key to deactivate the alarm system:

- the direction indicators flash once;
- the red LED **B** on the dashboard goes off;
- the central door locking system is activated and the doors are unlocked.

The alarm system is off and you can get into the vehicle and start the engine.

If the remote control battery is flat, to access the vehicle, you must use the spare key or replace the battery as described below.

Alarm memory

If the red LED **B** flashes when you have deactivated the system by means of the radio control, it means that the alarm was triggered while you were away. In this case, the system will indicate the reason for the alarm according to the following priority:

- *LED off twice*: lifting sensor alarm;

- *3 LED off three times*: door alarm;
- *LED off four times*: engine compartment lid alarm;
- *LED off five times*: ignition key alarm.

The alarm system memory is reset when you turn the ignition key.

Ministerial homologation

The electronic alarm system has been homologated in all the countries where radio frequency legislation is in force.

The homologation number is shown in the figure.

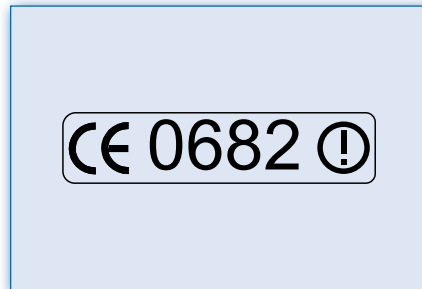

For those markets that require the transmitter and/or receiver marking, the homologation number is found on the component.

Requesting new keys

To purchase new keys with radio control, exclusively contact the **FERRARI SERVICE NETWORK**, bringing with you:

- all the keys with radio control in your possession;
- the **CODE CARD** for the **FERRARI CODE** system and the red **CODE CARD** for the alarm system;

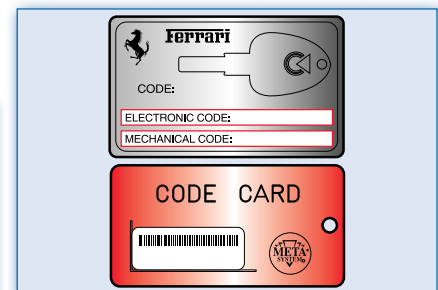

- a personal ID document;
- the registration documents proving ownership of the vehicle.

Keys with remote control that are not provided to the Ferrari Network centre, for the new code storage procedure, will automatically be deactivated. This is to prevent any lost or stolen keys with remote control from being used to deactivate the electronic alarm system.

F430

If you accidentally activate the alarm during engine starting, the engine starts normally and the alarm siren will be activated after 30 seconds. To deactivate it, press the remote control button on the key.

Replacing the radio control batteries

If the corresponding function is not activated when the key button is pressed, replace the radio control battery after checking with the other radio control that the alarm system functions work.

To replace the radio control battery:

- detach the key cover **A** prising with a small screwdriver at the point indicated by the arrow

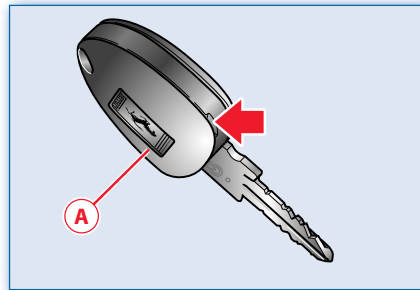

- remove the battery **B** by pushing it out from under the retaining spring clip **C** in the direction indicated by the arrow

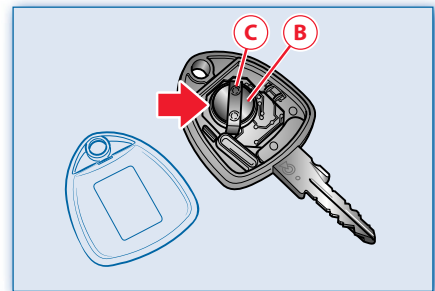

- fit a new battery of the same type, respecting the polarity indicated
- close the key cover **A**.

Do not use sharp tools to separate the key cover and be extremely careful not to damage the radio control.

2 - About your vehicle

Steering wheel controls

- ① Key switch
- ② Start button
- ③ Driving mode switch
- ④ Horn control
- ⑤ UP gearshift lever (*)
- ⑥ DOWN gearshift lever (*)
- ⑦ Exterior lights and direction indicator control lever
- ⑧ Windscreen and headlight wiper/washer control lever
- ⑨ Steering wheel adjustment lever

(*) for versions with F1 gearbox only

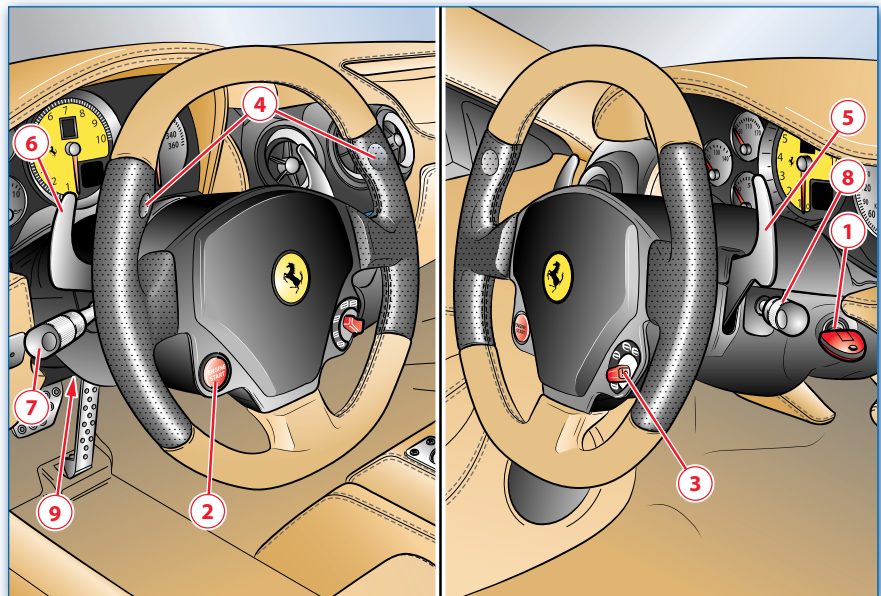

F430

1 - Key switch

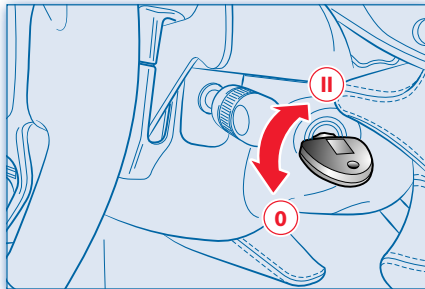

The ignition key can be turned to 2 positions:

Position 0 - Stop

Engine off, key removable.

When the key is even only partially extracted, the steering column is locked.

The hazard warning lights and the parking lights can be turned on.

To facilitate steering wheel release, turn the steering wheel slightly in both directions while turning the ignition key.

Position II - Start

When turning the key to this position, the system checks the signals coming from the systems installed on the vehicle. If no faults are found, the words **CHECK OK** light up and the engine can be started.



Never remove the key when the vehicle is moving!

The steering wheel will lock on the first

steer.

**Always remove the key from the ignition block when you get out of the vehicle!
Never leave children unattended in the vehicle.**

2 - Start button

Press the **ENGINE START** button to start the engine. When the engine has started, release the **ENGINE START** button.

Do not hold the **ENGINE START** button down for a long time.

For the starting procedure, see “Starting and driving the vehicle” on page 67 or 71.

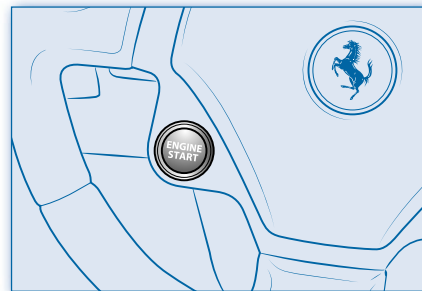

3 - Driving mode selection switch

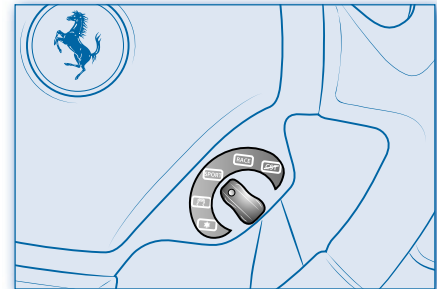

Whichever driving mode you select, always follow the rules for safe driving.

You can select the driving mode to suit the driving style you desire.

In the event of a failure of one of the onboard systems, signalled by the dedicated warning light on the instrument panel display (see page 35), the switch moves to a “recovery” position, allowing the vehicle to be driven nevertheless. In these cases, contact the FERRARI SERVICE NETWORK.

2 - About your vehicle

(❄️) "ICE" mode

This mode can be used when the road conditions are particularly slippery (snow, ice).

When this mode is activated, the **ICE** symbol will appear on the multi-function display for a few seconds and an acoustic signal will warn the driver that the driving mode has been changed.

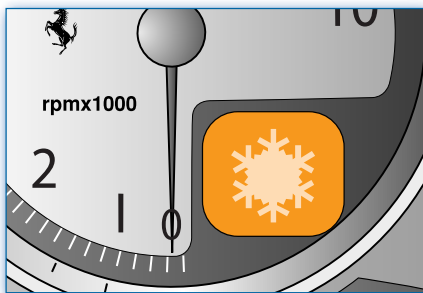

For use, see on [page 76](#).

(🚗) "Low-grip" mode

It can also be activated to enhance driving comfort even when driving in racing style, assuring stability in low- to medium- grip conditions. It is also recommended for city driving.

When this mode is activated, the **Low Grip** symbol appears on the multi-function display for a few seconds and an acoustic signal will warn the driver that the driving mode has been changed.

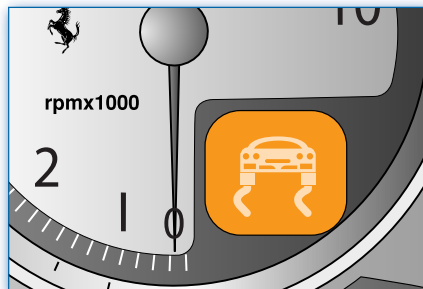

For use, see on [page 76](#).

SPORT mode

This is the ideal vehicle use condition.

Select **SPORT** mode if you wish to drive in racing style in high-grip conditions.

When this mode is activated, the **SPORT** symbol will appear on the multi-function display for a few seconds and an acoustic signal will warn the driver that the driving mode has been changed.

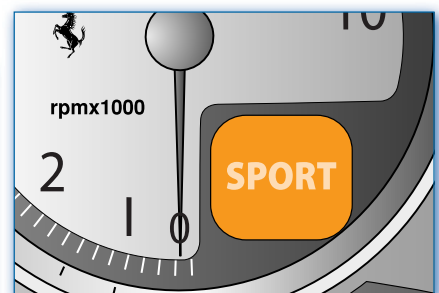

For use, see on [page 76](#).

F430

RACE mode

The **RACE** mode further enhances the already racing style performance of the vehicle. When this mode is activated, the **RACE** symbol will appear fixed on the multi-function display.

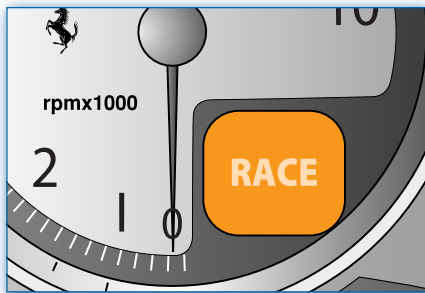

This selection is ideal for the race track.
For use, see on [page 76](#).

Deactivating the CST system (CST)

Selecting this mode you can deactivate the CST system (always on upon engine start). When this mode is deactivated, the relevant warning light on the instrument panel will come on and the **CST** symbol will appear on the multi-function display.

An acoustic signal will sound at length to warn the driver that the driving mode has been changed.

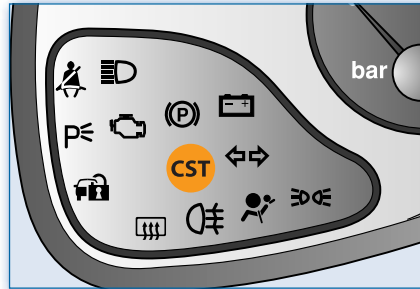

When the CST system is active, its operation is signalled by the relative warning light on the instrument panel and by the (green) message **CST ACTIVE** on the multi-function display, which flashes for at least 4 seconds.



In low- to medium-grip conditions (wet, icy, sandy roads), do not deactivate the CST system.

When the CST system is active and the amber warning light comes on, it means that there is a fault in one of the system parts. Contact the **FERRARI SERVICE NETWORK**.

Every time the ignition is switched on further to this operation, the CST system will reactivate.

For use, see on [page 76](#).

2 - About your vehicle

4 - Horn control

The horn is activated by pressing by the sides of the upper spokes on either side of the steering wheel, in position with the horn symbol.

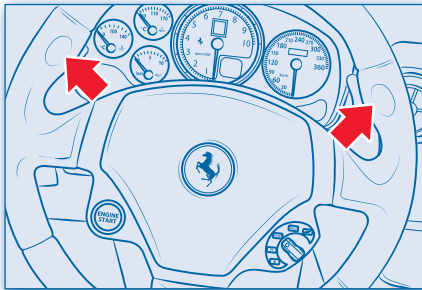

5 - UP gearshift lever (vehicles with F1 gearbox)

Pull the right-hand **UP** lever towards the steering wheel to shift up.

For use, see “Starting and driving the vehicle” on [page 67](#).

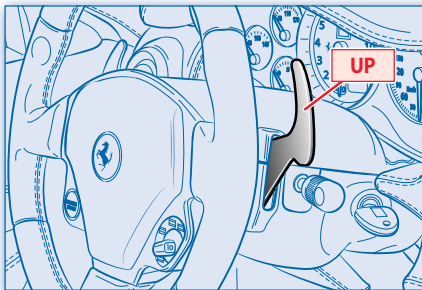

6 - DOWN gearshift lever (vehicles with F1 gearbox)

Pull the left-hand **DOWN** lever towards the steering wheel to shift down.

For use, see “Starting and driving the vehicle” on [page 67](#).

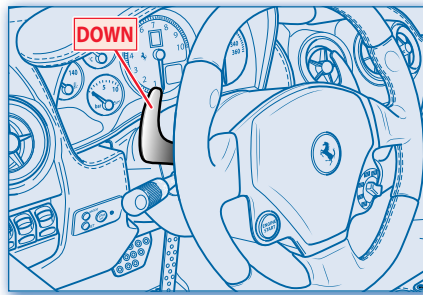

7 - Exterior lights and direction indicator control lever

The exterior lights and the direction indicators only work when the ignition key is in position **II**.

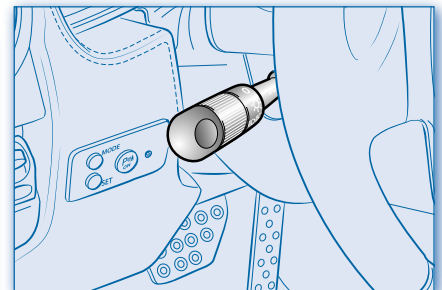

F430

Operate the lever to activate:

- **the exterior lights:**

Position **0**:

Lights off.

Position **1** (lever turned by one click):

Position lights and number plate lights on (the relevant warning light also comes on) and the instrument panel is backlit.

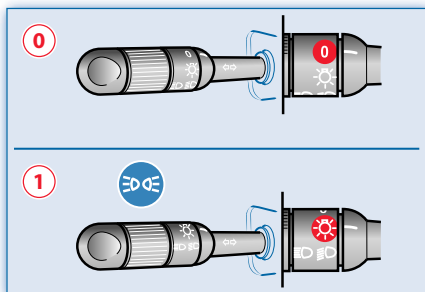

Position **2** (lever turned by two clicks):

Low beams on.

Position **3** (lever pushed forward):

High beams on (the relevant warning light also comes on).

The high beams can only be switched on with the lever in position **2**.

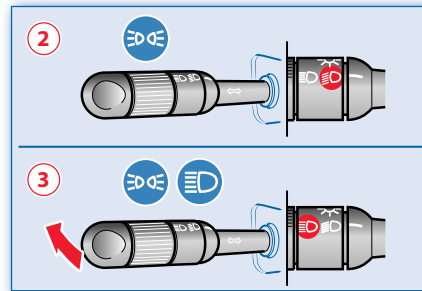

- **headlight flashing:**

with the high beams, it is activated by pulling the lever towards the steering wheel.

The function can be activated with the lever in any position.

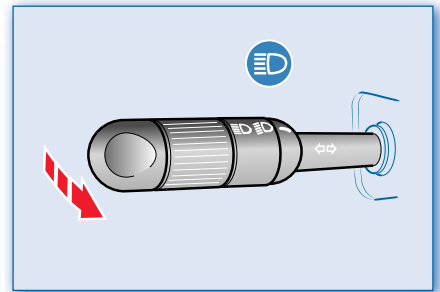

2 - About your vehicle

- direction indicators

The direction indicators work only when the ignition key is in position II.

The instant the lever is moved, the relevant warning light on the instrument panel also comes on.

The lever returns to its central position when the steering wheel is straightened.

Position A (lever in rest position):

Direction indicators off.

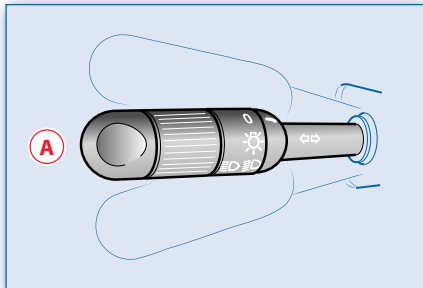

Position B (lever up):

Right-hand side indicators.

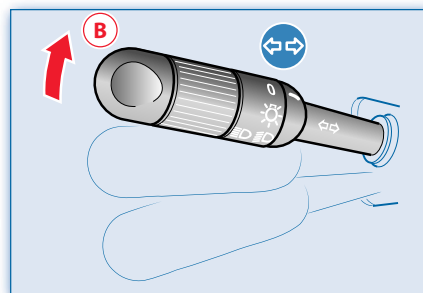

Position C (lever down):

Left-hand side indicators.

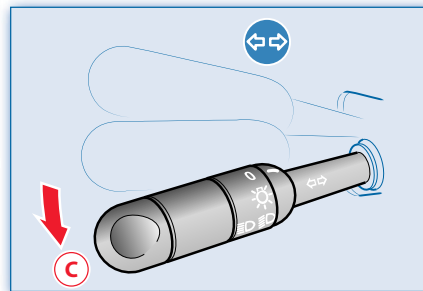

8 - Windscreen wiper and washer control lever

The windscreen wiper and washer operate only with the ignition key in position II.

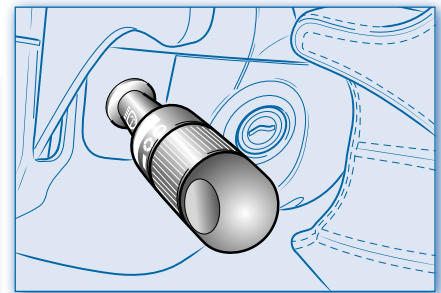

Operate the lever to activate:

- the windscreen wiper:

Position 0:

Windscreen wiper off.

Position I (lever lowered by one click):
Adjustable intermittent operation.

Position II (lever lowered by two clicks):
Continuous slow operation.

Position III (lever lowered by three clicks):
Continuous fast operation.

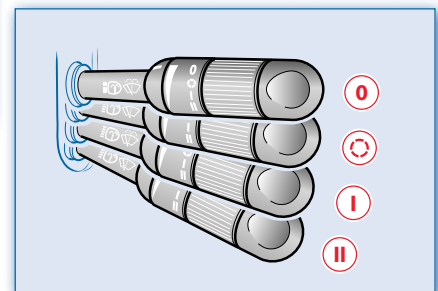

F430

- to adjust the intermittent speed:

In position , turn the lever to change the intermittent speed:

- **clockwise** = slower intermittent speed;
- **anticlockwise** = faster intermittent speed.

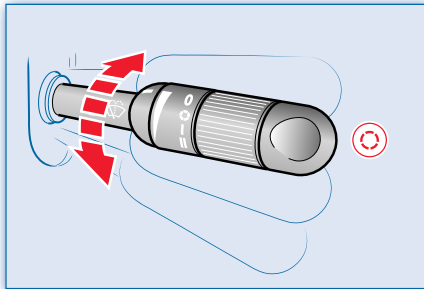

- windscreen washer:

Pull the lever towards the steering wheel **A** to simultaneously activate the windscreen washer and the windscreen wiper.

When the lever is released, the windscreen washer stops while the windscreen wiper runs a few more strokes.

- headlight washers:

Push the lever in the opposite direction to the steering wheel **B** to activate the headlight washers. When the lever is released, the spray nozzles go back into their seats.

For better cleaning, use the headlight washers when the vehicle speed is below 130 km/h (80 mph).

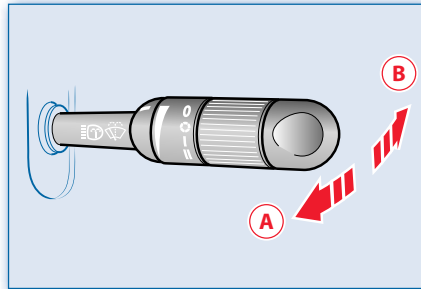

9 - Steering wheel adjustment lever

The steering wheel can be adjusted in height and depth.

- Release the lever by pulling it towards the steering wheel.
- Adjust the steering wheel position.
- Lock the steering wheel by pushing the lever back to its original position.

Do not adjust the steering wheel when the vehicle is moving.

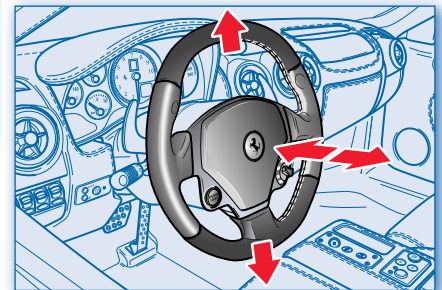
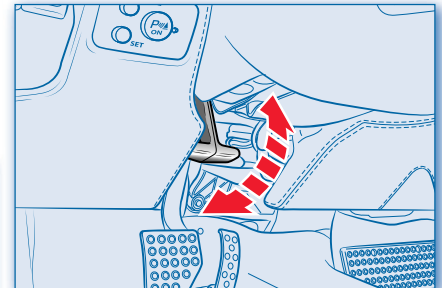

2 - About your vehicle

Instrument panel

- ① Electronic speedometer
- ② Rev. Counter
- ③ Oil pressure gauge
- ④ Oil temperature gauge
- ⑤ Water temperature gauge
- ⑥ Fuel level gauge
- ⑦ Gear display (*)
- ⑧ Warning lights display
- ⑨ Multi-function display

(*) for versions with F1 gearbox only.

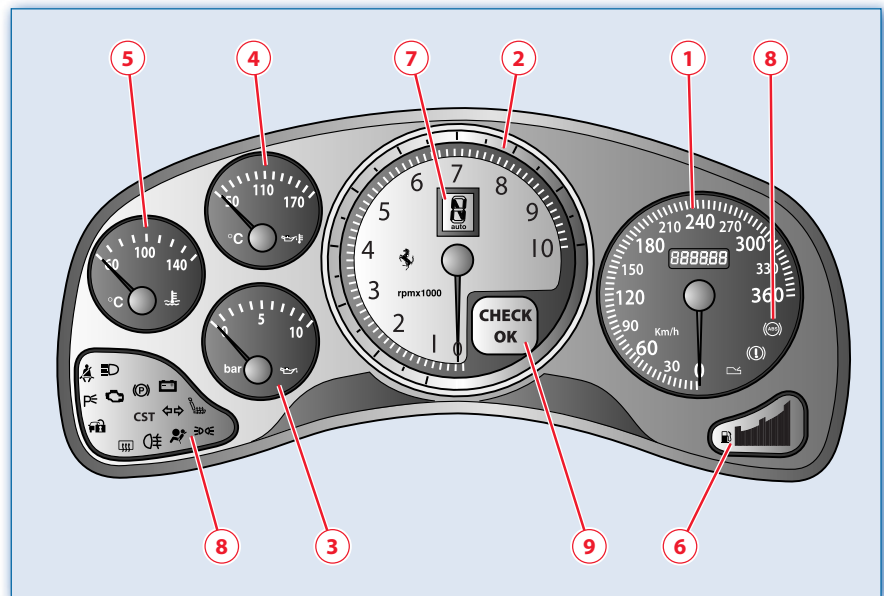

F430

1 - Electronic speedometer

Indicates the vehicle speed.

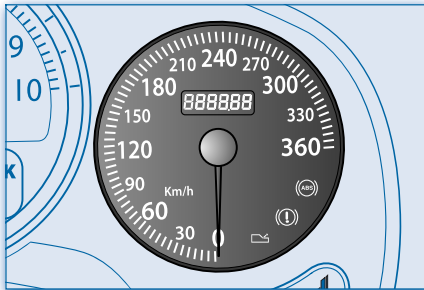

Odometer:

Briefly press button **SET** to display the total **B** or trip **C** mileage on the instrument panel.

To reset the trip kilometres, hold button **SET** pressed down for at least 2 seconds.

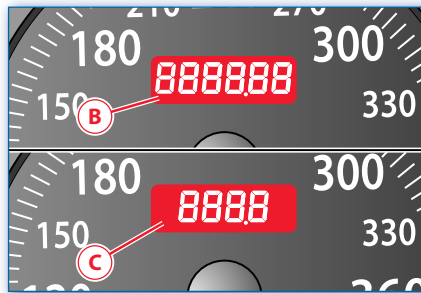
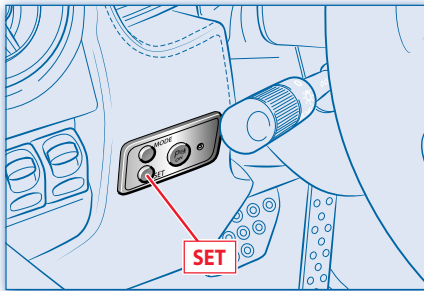

2 - Rev. Counter

Indicates the engine rpm.

*Avoid engine speeds in the red sector.
If you exceed the rpm, the ignition/injection ECU will temporarily cut off the fuel supply.*

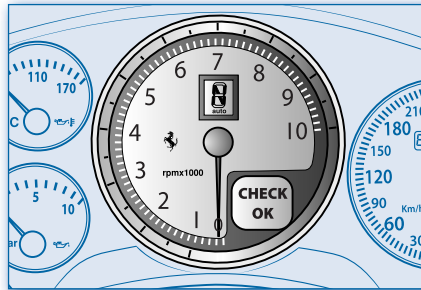

3 - Engine oil pressure gauge

The red warning light **D** indicates insufficient pressure.

In normal conditions, it comes on before starting in order to run a self-test.

If a failure occurs, it lights up when the engine is running and pressure is insufficient. In this case, turn the engine off immediately and carry out the necessary checks.

If the problem persists, contact the **FERRARI SERVICE NETWORK**.

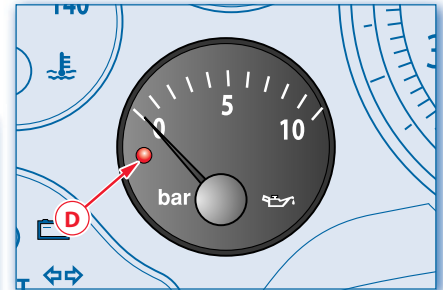

2 - About your vehicle

4 - Engine oil temperature gauge

When the red warning light **E** comes on, it indicates that the temperature is too high, i.e. above 155°C (311 °F). In this case, reduce the engine speed immediately. If the temperature remains high, turn off the engine and contact the **FERRARI SERVICE NETWORK**.

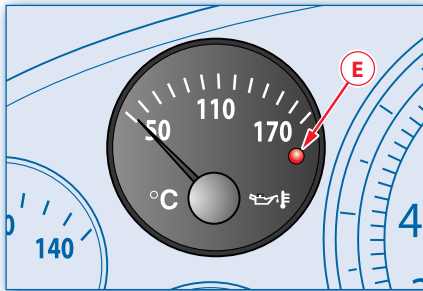

5 - Water temperature gauge

Indicates the coolant temperature. When the red warning light **F** comes on, it indicates that the temperature is too high. This light comes on when the temperature exceeds 125°C (257 °F). In this case, reduce the engine speed rate immediately. If the temperature remains high, turn off the engine and contact the **FERRARI SERVICE NETWORK**.

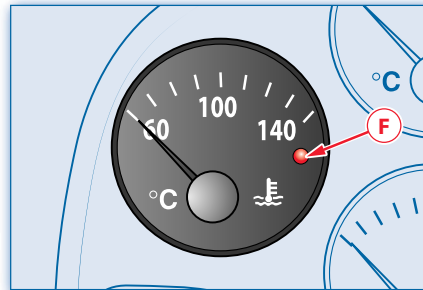

6 - Fuel level gauge

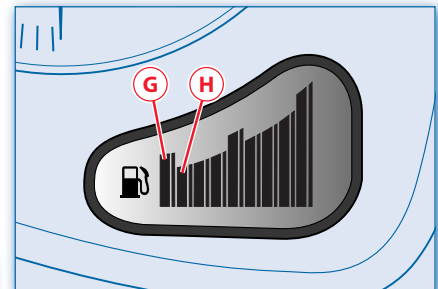

If the last segment **G** on the fuel level gauge flashes and the second before last segment **H** is on fixed, it means that there are 18-20 litres (3.96-4.4 Imp.Gall.) of fuel left in the tank.

When there are less than 9 litres (1.98 Imp.Gall.) of fuel left, the symbol **I** appears on the multi-function display and the last segment of the gauge goes off.

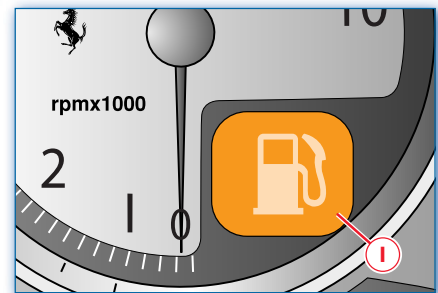

F430

7 - Gear display (for versions with F1 gearbox only)

Incorporated in the rev counter; with the ignition key in position **II**, it displays the gear engaged.

N - Neutral

R - Reverse gear

I - 1st gear

2 - 2nd gear

3 - 3rd gear

4 - 4th gear

5 - 5th gear

6 - 6th gear

auto - automatic gearshift

When the symbol  is displayed, it indicates a fault condition in the gearbox. Please contact the **FERRARI SERVICE NETWORK** to have the necessary checks carried out.



Warning lights

8 - Warning lights display

If a failure warning light comes on while driving, have the necessary checks carried out at the **FERRARI SERVICE NETWORK**.

As well as coming on when the self-check is run before starting, the warning lights may switch on in the following cases:

ABS



While driving, to indicate malfunctioning of the ABS system.

*The standard brake system remains functional - contact the **FERRARI SERVICE NETWORK**.*

Brake failure



To indicate insufficient brake/clutch fluid in the tank.

To indicate excessive wear of the front brake pads (also the rear ones in the case of optional CCM system).

*If the warning light comes on while driving, stop the vehicle, check the level of fluid in the tank and contact the **FERRARI SERVICE NETWORK**.*

CST system failure

CST To signal that the CST system is deactivated or to indicate a failure of one of the systems in the CST.

*In the latter case, contact the **FERRARI SERVICE NETWORK**.*

Moreover, when the warning light flashes it indicates that the CST system has cut in.

Parking brake



When the parking brake is engaged.

Airbag



While driving, to indicate a malfunction in the airbag system and/or in the seat belt pretensioners.

*If the warning light does not come on for the self-check or if it switches on while driving the car, contact the **FERRARI SERVICE NETWORK** immediately.*

Seat belts



With the ignition key turned to position **II** when the driver's seat belt is not fastened.

Alternator



If there is a fault in the recharging system.

When the battery is insufficiently charged or overcharged (flashing).

F1 gearbox failure



Comes on permanently, emitting a beep when an F1 gearbox operating error has occurred.

*If the failure permits, pull off the road and contact the **FERRARI SERVICE NETWORK**.*

Flashing: low pressure in the system.

2 - About your vehicle

Engine control system malfunctioning



While driving, to indicate a malfunction in the emission control system and in the ignition/injection system.

It remains on for a self-check cycle from the instant the ignition key is turned to position **II** until a few seconds following the engine starting.

For further information see [page 116](#).

Direction indicator



When the direction indicators are turned on.

When the hazard warning lights are turned on.

Position lights/low beams



When the position lights or low beams are turned on.

High beams



When the high beams are turned on.

When the high beams are used to flash.

Parking lights



When the parking light control switch is activated.

Rear fog lights



When the rear fog lights are turned on.

Heated rear window and exterior rear view mirror defroster



When the button which controls the heated rear window and the exterior rear view mirror defroster is operated.

They will automatically switch off thirty minutes after they have been activated.

Ferrari CODE system



The vehicle is equipped with an electronic engine immobilizer system (FERRARI CODE), which is activated automatically when the ignition key is removed.

The keys are equipped with an electronic device that transmits a coded signal to the immobilizer ECU, which allows the engine to be started only if it is recognised.

Seat heating (optional)



When the seat heater is activated (see [page 49](#)).

Failure of all the braking systems and CST



When the warning lights shown in the figure come on at the same time:

CST



Caution: Danger of rear wheels locking due to malfunctioning of the electronic brake-force distribution system and possibility of spinning.

Stop the car without braking sharply. Do not drive any further and immediately contact the FERRARI SERVICE NETWORK.

The car may still be driven at low speed (max. 40 km/h - 25 mph) in order to pull off the road.

F430

Multi-function display

9 - Multi-function display

Incorporated in the instrument panel, its function is to diagnose and signal any faults; it may have the following colours:

Green = Normal driving conditions

Red = When a fault occurs

Amber = When one of the available systems has been activated

Multi-function display signals

The multi-function display shows symbols relative to fault conditions and the state of the vehicle.

If more than one fault occur at the same time, they are displayed for a length of time depending on their priority.

The signals of the tyre pressure monitoring system (optional) that may appear on the multi-function display are described on page 126.

The following symbols may be displayed:

Check OK



When the ignition key is turned to Position **II**, the electronic system runs a diagnostic check of the vehicle and, if no faults are found, the symbol **Check OK** comes on to indicate that the vehicle can be started.

Fuel tank flap open



Indicates that the fuel tank flap is open or not properly closed.

Outside temperature



If selected with the relevant button, it displays the outside temperature.

Clock



Displays the time in standard mode. It can be disabled with the multi-function button (see page 40).

If the battery is removed, the exact time will have to be reset using the multi-function buttons (see page 40).

CST active



While driving, it indicates that the CST has cut in.

CST inactive



Indicates a malfunction or that the CST system has been deactivated with the switch on the steering wheel (see page 24).

Low fuel



Indicates that 18-20 litres (3.96-4.4 Imp.Gall.) of fuel are left in the tank or that the level gauge is malfunctioning.

Fuel supply cut-off



Indicates that the inertia switch has tripped, in the event of an accident, and that consequently the fuel supply has been cut off.

Suspension system



While driving, it indicates a malfunction in the suspension system.

Contact the **FERRARI SERVICE NETWORK**.

Instrument panel lighting



If selected with the relevant button, it displays the adjustable brightness level of the instrument panel (see page 40).

Slow Down



While driving, it indicates a too high temperature in the exhaust system (see page 115).

Indicates temporary malfunctioning of the electronic differential (see page 117).

Contact the **FERRARI SERVICE NETWORK**.

Hazard warning lights



If on, it signals that all the direction indicators are on at the same time.

2 - About your vehicle

Windscreen washer fluid



Indicates that there is insufficient fluid in the windscreen washer tank.

Luggage and engine compartment lids open



Indicates that the luggage and engine compartment lids are open or not properly closed.

Luggage compartment lid open



Indicates that the luggage compartment lid is open or not properly closed.

Engine compartment lid open



Indicates that the engine compartment lid is open or not properly closed.

Left- and right-hand doors open



Indicates that the doors are open or not properly closed.

Left-hand door open



Indicates that the driver-side door is open or not properly closed.

Right-hand door open



Indicates that the passenger-side door is open or not properly closed.

Battery charger connected



When the instrument panel is on, it indicates that the battery charger is still connected.

ICE mode setting



When the ICE driving mode is selected on the steering wheel switch (see [page 23](#)).

Vehicle set to Low-grip mode



When Low-grip driving mode is selected, on the steering wheel switch (see [page 23](#)).

Vehicle set to SPORT mode



When SPORT driving mode is selected on the steering wheel switch (see [page 23](#)).

SPORT mode changes the driving performance of the vehicle.

Vehicle set to RACE mode



When RACE driving mode is selected on the steering wheel switch (see [page 24](#)).

RACE mode changes the driving performance of the vehicle.

Electronic differential



The amber symbol indicates that the electronic differential clutch is overheating: reduce speed.



The same symbol in red indicates an E-DIFF system failure. In these cases, the vehicle can still be driven, but without the aid of the electronic differential.

■ [Contact the FERRARI SERVICE NETWORK.](#)

Driving mode switch failure



Indicates a failure of one or more systems that define the selected driving mode.

■ [Contact the FERRARI SERVICE NETWORK.](#)

Brake Service (only vehicles with CCM brake system)



Indicates that the wear limit of the carbon brake discs has been reached.

■ [Contact the FERRARI SERVICE NETWORK.](#)

F430

Dashboard controls

- ① Fuel filler cap flap opening button
- ② Rear fog lights button
- ③ Heated rear window and exterior rear view mirror defrost button
- ④ Luggage compartment lid opening button
- ⑤ Multi-function buttons (MODE, SET)
- ⑥ Power window control
- ⑦ Car stereo system
- ⑧ Air conditioning and heating system controls (for use see [page 62](#))
- ⑨ Document compartment opening button (for use see [page 57](#))
- ⑩ Calibration button for the tyre pressure monitoring system (TPMS), optional (for use see [page 125](#))
- ⑪ Front parking sensor deactivation button (optional) (for use see [page 77](#))

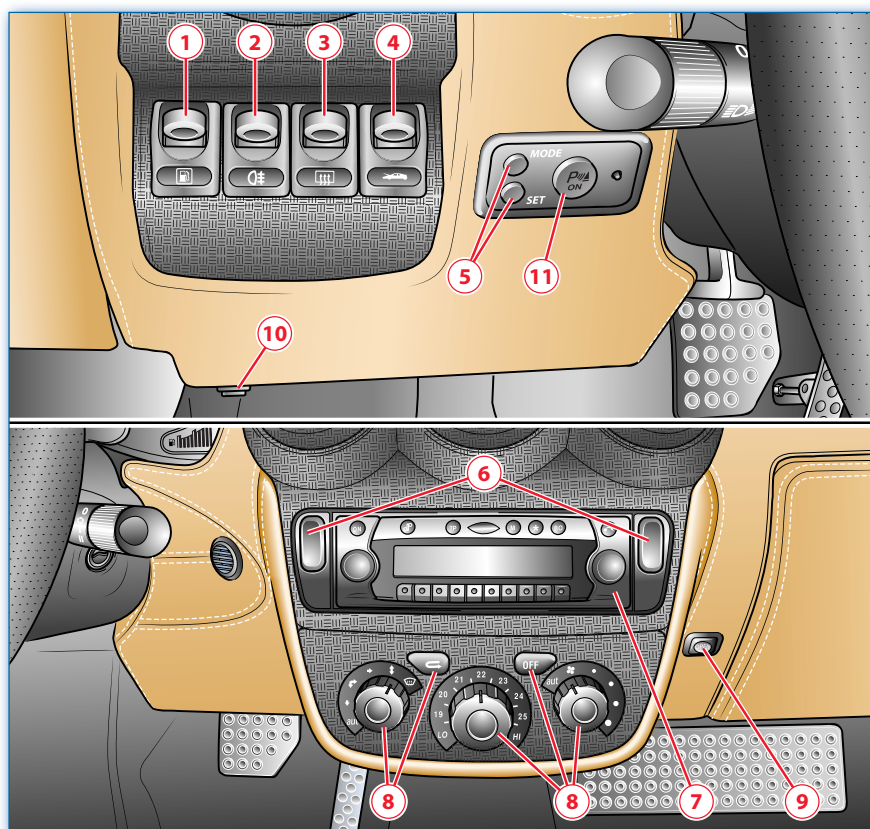

2 - About your vehicle

1 - Fuel filler cap flap opening button

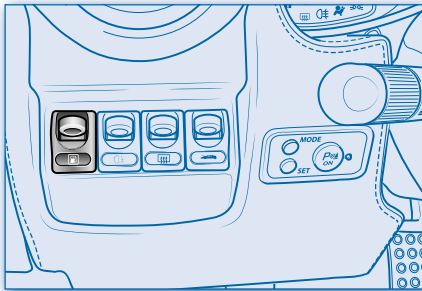

Opening

With the key in position 0, push the release button to unlock the access flap to the fuel filler cap.

Unscrew the cap **A** turning it anticlockwise and hang it on the dedicated hook **B**.

Caution: It is perfectly normal if air is released when the cap is unscrewed. The airtight seal of the tank filler neck may cause slight pressure to build up in the system.

Always switch off the engine during refuelling. Take extreme care when removing the cap.

 Do not smoke or use naked flames when refuelling; furthermore, inhaling vapours can be harmful.

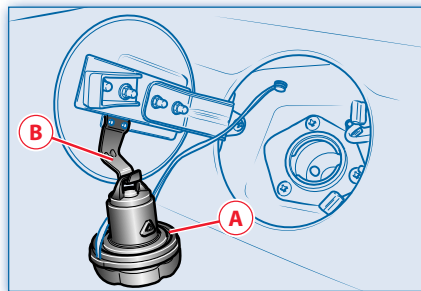

Closing

• Screw the cap **A** back on and close the compartment by pressing on the flap. Make sure that the cord **C** does not hang out of the fuel filler cap compartment.

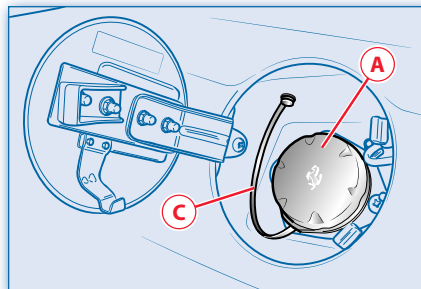
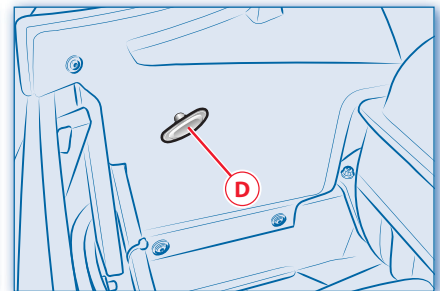

Emergency opening

If the opening button does not work, the flap can be opened manually by pulling the lever **D** located on the left-hand side of the engine compartment.

F430

2 – Rear fog lights button

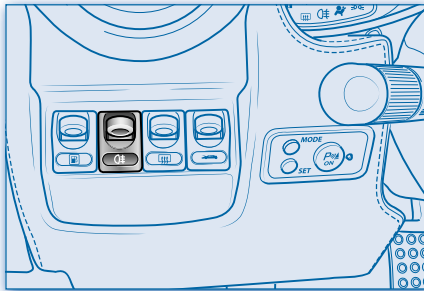

When the button is pressed, the rear fog lights are turned on only if the high beams or low beams are on. The relevant warning light on the instrument panel comes on to indicate that they have been turned on.

 Use the rear fog lights only in poor visibility conditions.

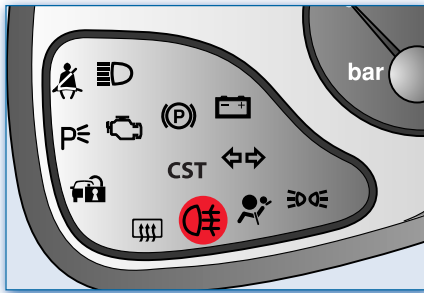

3 – Heated rear window and exterior rear view mirror defroster button

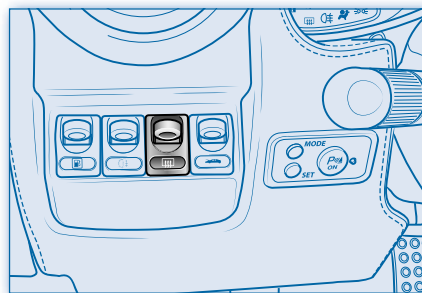

The defroster is activated by pressing the button on the dashboard. The relevant warning light on the instrument panel comes on to indicate activation.

30 minutes after activation, the control button will automatically be turned off. It is however advisable to switch it off when the demisting or defrosting procedure has been completed.

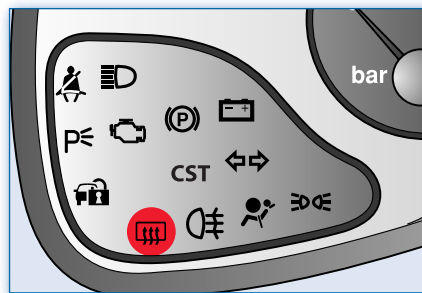

4 – Luggage compartment lid opening button

The lid can also be opened with the ignition key off.

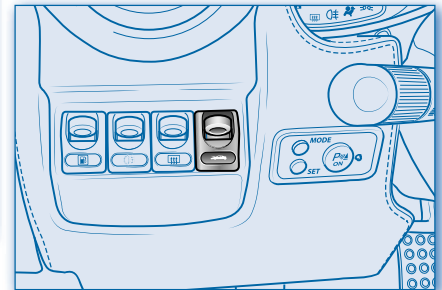

Opening

Push the release button on the dashboard. Stand in front of the vehicle, slightly lift the lid and press on the retaining lever **E** to lift it completely.

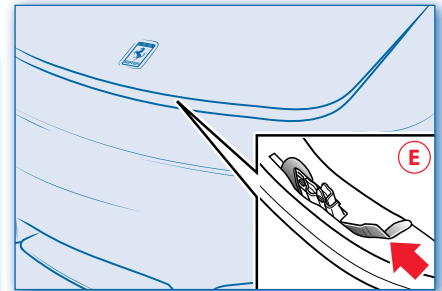

2 - About your vehicle

The lid is held open by two gas struts.
The luggage compartment is illuminated by a courtesy light.

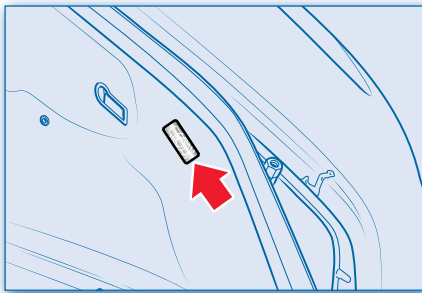

Closing

Lower the lid until it is closed and press down near the lock until you hear it click in place.

 Always check that the lid is closed properly to prevent it from opening while driving.

Emergency opening

If the opening button malfunctions, pull the lever located under the dashboard, on the left-hand side of the steering column.

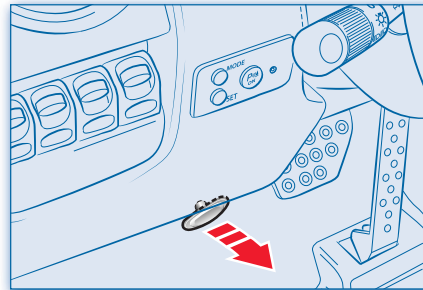

5 - Multi-function buttons

The multi-function buttons work only when the ignition key is in position **II**.
In standard operating mode, the time is displayed on the multi-function display.



Briefly press the left-hand button **MODE** (less than 2 seconds) to sequentially switch between the various functions shown on the display:

- Outside temperature
- FL - front left tyre pressure (*)
- FR - front right tyre pressure (*)
- RR - rear right-hand tyre pressure (*)
- RL - rear left-hand tyre pressure (*)

(*) This function can be activated only when the tyre pressure monitoring system has been installed (optional)

Press the left-hand button **MODE** for longer than 2 seconds to enter the programming mode, where you can scroll through the options by briefly pressing the

F430

same button.

Four options are available:

- adjusting the instrument panel brightness
- switching the clock ON/OFF
- setting the hours
- setting the minutes.

Within each specific area, briefly press the right-hand button **SET** to make the following adjustments:

- increase the instrument panel brightness
- switch the clock ON/OFF
- increase the hours
- increase the minutes.

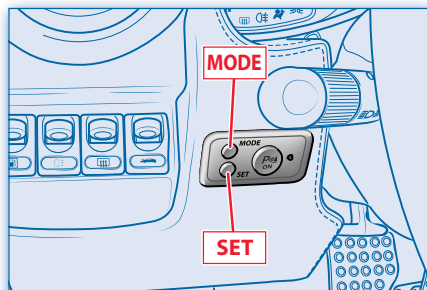

The programming mode is exited if no button is pressed for more than 10 seconds (timeout) or after the left-hand button **MODE** has been pressed briefly from the minute-setting option.

In standard mode, briefly pressing the right-hand button **SET** switches the odometer between trip and total kilometres,

whereas pressing the right-hand button for a longer time resets the trip odometer (see page 30).

Outside temperature display

Briefly press the left-hand button **MODE** to display the outside temperature on the multi-function display.

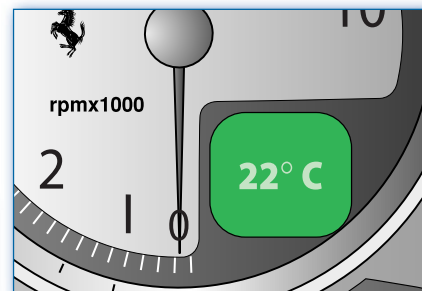

Instrument panel lighting

Press the left-hand button **MODE** for a longer time to display the symbol on the multi-function display.



Briefly press the right-hand button **SET** to adjust the brightness of the instrument panel to a value between 0 and 30.

Clock

If you do not wish to display the time, press the left-hand button **MODE** for a longer time, press it briefly again and select OFF. In this case, the time is not displayed even when the ignition key is subsequently turned to position **II**.

If you wish to display the time again, the procedure described must be repeated, selecting the option ON.

When the battery is disconnected, the clock stops. When the battery is reconnected, the exact time must be reset using the multi-function buttons as described earlier.

If one or more alarm symbols appear on the multi-function display, the time will not be displayed as long as the alarm is active.

As you can travel for long distances with several warnings on, the following may

2 - About your vehicle

be shown simultaneously on the multi-function display: time and **CST** deactivated symbol, low fuel symbol or **RACE** driving mode.

Any other messages on the multi-function display will be shown according to the display sequence described earlier.



6 - Power window control

The power windows can only be used with the ignition key in position **II**.

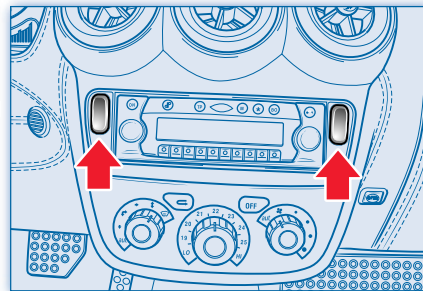

Driver-side power window control

It is operated by pressing the button to the left of the car stereo system.

This button allows manual operation (partial opening/closing) or automatic operation (complete opening/closing): press the button briefly to activate manual

operation; hold the button down for a longer time (more than 0.3 seconds) to activate automatic operation so that the window stops when it reaches the end of its travel, or press the button a second time.

Passenger-side power window control

It is activated by pressing the button to the right of the car stereo system

This button allows only manual operation: when the button is released, the window stops at the position reached.

The window can move up to the "target" position in order to prevent the door from colliding with the upper weather strip when closing it.

⚠ Improper use of the power window controls can be dangerous. Before use, always check that people and objects are at a safe distance.

Pay particular attention during automatic operation of the driver-side power window.

To protect the passengers remaining seated in the vehicle against accidental activation of the power windows, always remove the key from the ignition block.

F430

7 – Car stereo system

For use consult the Instruction Handbook contained in the bag on board the vehicle.

The system is made up of the following components:

- Car stereo with removable front panel.

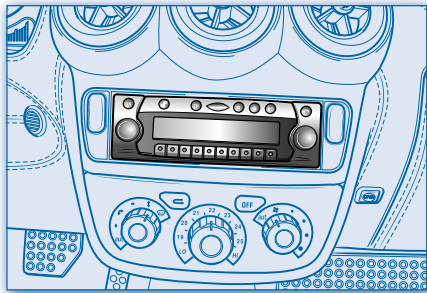

- 2 Woofer loudspeakers fitted at the bottom of the door panels.
- 2 Tweeter loudspeakers fitted on the interior fixing plate for the exterior rearview mirrors.

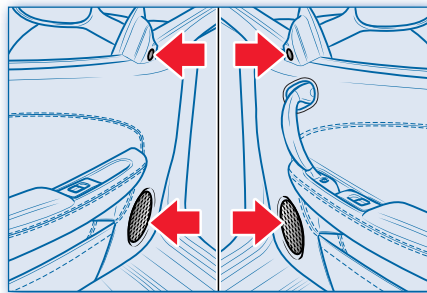

- Aerial incorporated in the windscreen.
- CD-changer on the left-hand side of the luggage compartment (optional).

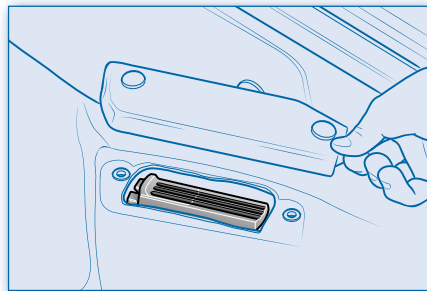

Various optional devices can be installed on the vehicle (satellite navigator, Bluetooth™, powered Hi-Fi, etc.). For their description, see the “Scaglietti Bodywork Programme” Owner’s manual.

Controls on the tunnel

- ① Hazard lights switch
- ② Parking lights switch
- ③ External rear view mirror controls
- ④ Parking brake lever
- ⑤ Mechanical gearbox lever
- ⑥ 12V power socket
- ⑦ Reverse gear engagement button (*)
- ⑧ "Automatic gearshift" function switch (*)
- ⑨ L.C. activation button (*)

(*) for version with F1 gearbox only: For their use, see "Starting and driving the vehicle (F1 gearbox)" on [page 67](#).

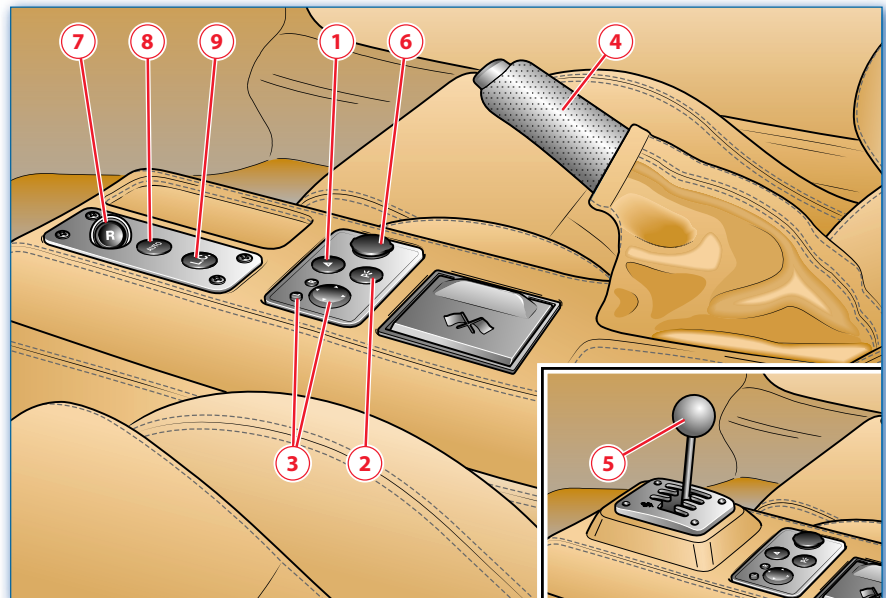

F430

1 – Hazard lights switch

Press the switch to turn on the hazard lights.

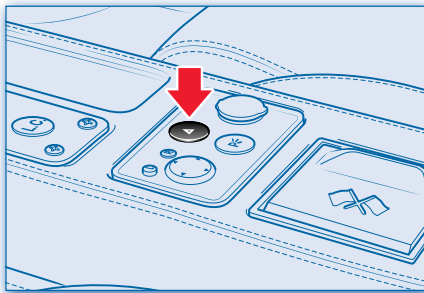

All the direction indicators will start to blink intermittently at the same time, independent of the ignition key position. The relevant symbol will be shown on the multi-function display and the warning light on the instrument panel and on the switch itself will flash intermittently to indicate that the hazard lights are on.

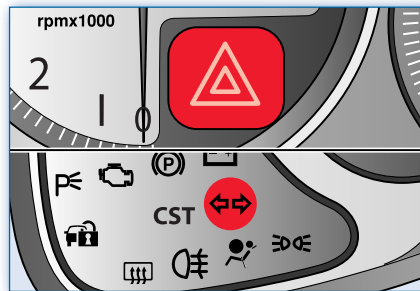

To turn them off, press the switch again.

2 – Parking lights switch

Press the switch to turn on the parking lights.

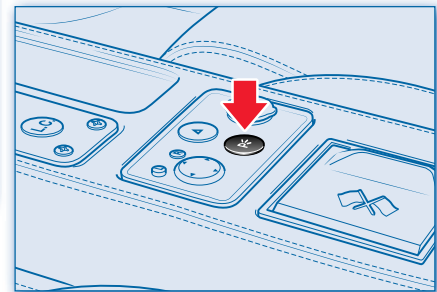

All the position lights will be turned on.

This operation is independent of the ignition key position.

The warning light on the instrument panel will come on to indicate that the parking lights are on.

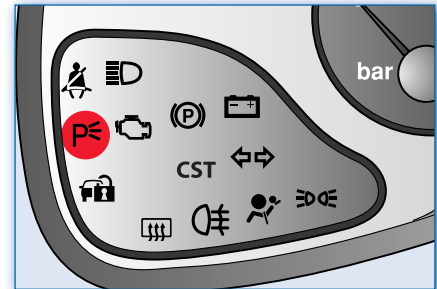

For deactivation, press the switch once again.

2 - About your vehicle

3 – External rear view mirror controls

The rear view mirrors can be electrically adjusted.

They can only be adjusted with the ignition key in position **II**.

To select the mirror you wish to adjust, operate the selector **R** (right-hand mirror) or **L** (left-hand mirror).

To adjust the mirror vertically or horizontally, push the adjustment button.

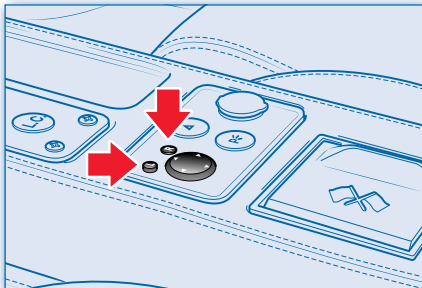

In case of need, the exterior rear view mirrors can be folded manually towards the outside or the inside.

⚠ The mirrors must be always positioned correctly while driving. Do not adjust the mirrors when the vehicle is moving.

4 – Parking brake lever

To engage the parking brake, pull the lever fully upwards thus locking the rear wheels.

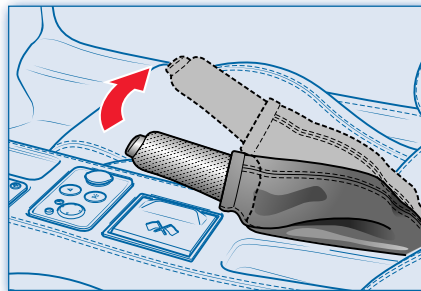

With the ignition key in position **II**, the warning light on the instrument panel comes on to indicate that the parking brake is engaged.

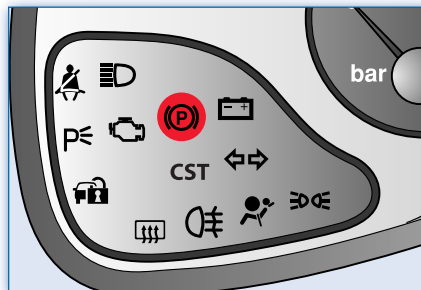

To release the parking brake, pull the lever upwards slightly and press the release button on the end of the lever **A**.

Fully lower the lever keeping the button pressed.

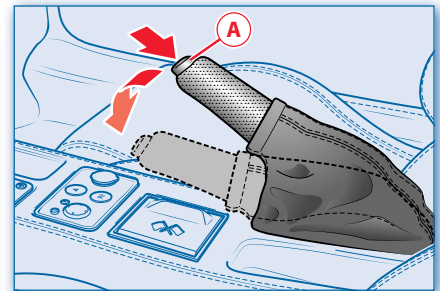

The warning light on the instrument panel will go off when the parking brake has been released completely.

⚠ Always use the handbrake when the vehicle is parked.

For further information see page 72.

F430

5 – Mechanical gearbox lever

For use of the gearshift lever see “Starting and driving the vehicle (Mechanical gearbox)” on page 71.

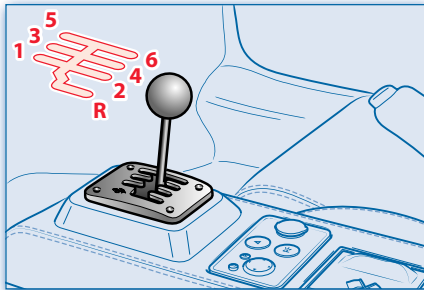

6 –12V power socket

This socket can be used to power small electrical devices such as: cell phone, lights, vacuum cleaner and any other accessory with absorption not higher than 140 Watts and 12 Volts.

 Prolonged use of this device may discharge the battery.
Do not try to insert plugs that are incompatible in size and shape into the power socket.

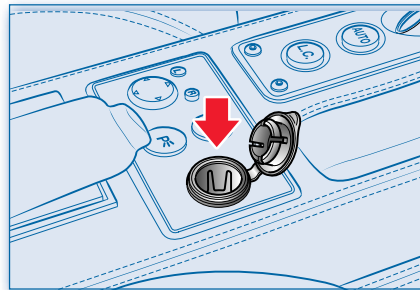

Doors

When the doors are opened or closed, the windows will automatically move down approximately 2 centimetres (0.8 in.) and stop (broken line) in order to prevent collision with the door weather strip. When the door is closed, the window automatically moves up until it meets the weather strip.

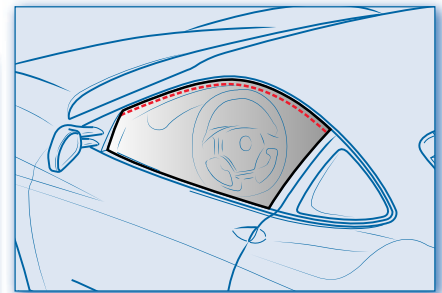

Opening the doors from the outside

Deactivate the alarm and the central locking via the radio control; should the latter not work, refer to section “Electronic alarm system” on page 18.

Lift the handle to open the door.

Activate central locking by turning the key clockwise.

2 - About your vehicle

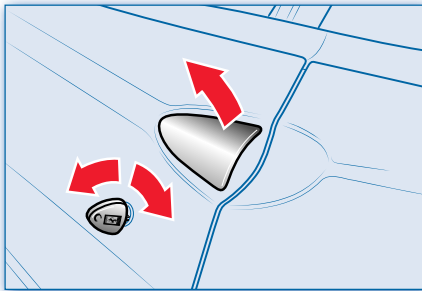

Locking and opening the doors from the inside

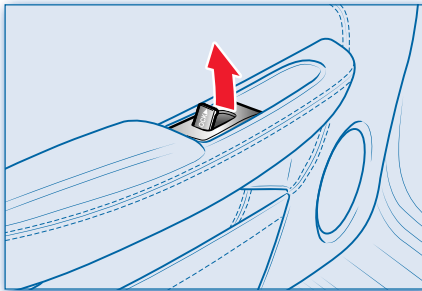

Both doors are locked by operating the small lever **LOCK**.

When using the handle to open the door, the window will move down to its “target” position.

When the door is closed, it will move back up until it meets the upper ledge.

If the handle is operated without opening the door, the window will move down to its “target position” and stop, and if the door

is not opened after 15 seconds, the window will move back up until it meets the upper ledge.

Therefore, to open the door release the handle and pull it again.

When the opening handle is operated, also both doors are unlocked.

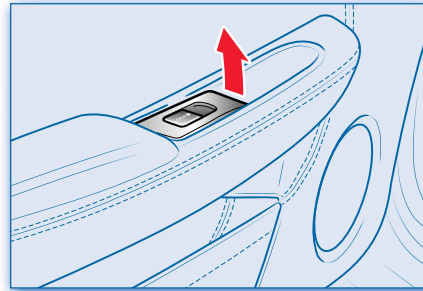

Door open' indicator

Each door is equipped with a red light that indicates their opening. This light comes on automatically when the door is opened.

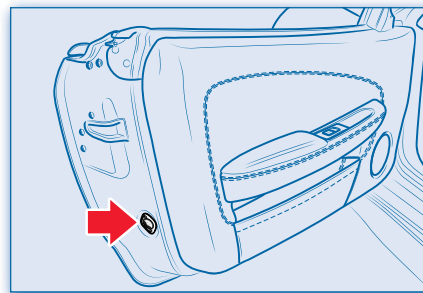

Seat controls

Proper seat adjustment is essential to obtain the best driving comfort and maximum effectiveness of the passive safety systems.

⚠ Never adjust the seat while driving, as you could lose control of the vehicle. Adjust the driver's seat only when the vehicle is standing.

Mechanically adjustable seat

Backward/forward adjustment

Pull the lever **A** upwards and slide the seat forward or backward to the desired position.

Release the lever and “wiggle” in the seat to check that it is locked in place.

Backrest inclination

Turn the knob **B** until the desired inclination has been reached.

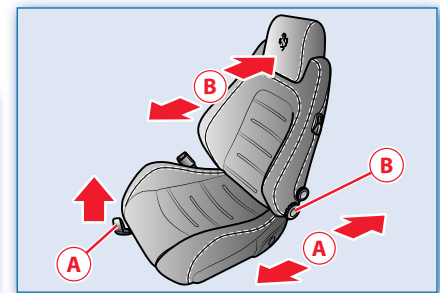

F430

Lumbar support

Turn the knob **C** until the desired arching of the lumbar area has been reached.

Side supports

Turn the knob **D** to obtain the desired width of the side supports.

Backrest tilting

Operate the lever **E** to tilt the backrest forward.

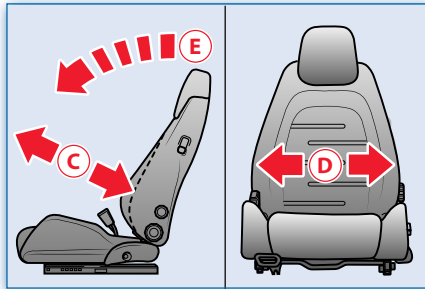
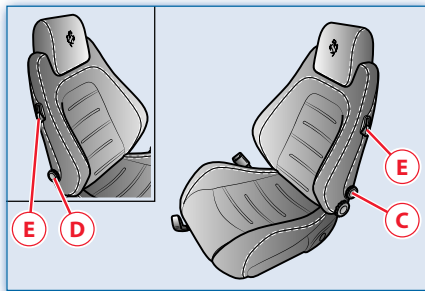

Electrically adjustable seat

The seats can only be adjusted with the ignition key in position II. With the door closed, the seat can be activated for about 15 seconds after turning the ignition key to position 0 and subsequently for a further 15 seconds from the last activation.

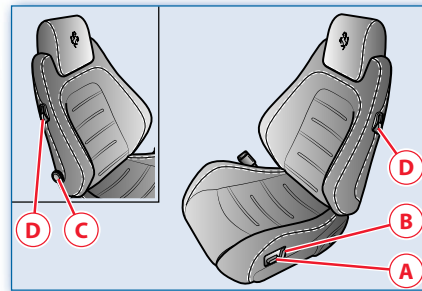

Backward/forward and height adjustment

Operating the control you can **A**:

- slide the seat forward and backward
- slide the seat up and down
- adjust the inclination of the seat cushion clockwise or anticlockwise.

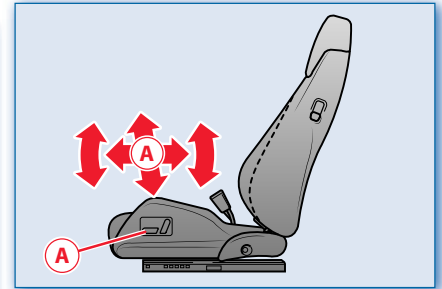

Backrest inclination and lumbar support

Operate the control **B** to incline the backrest to the desired position or to obtain the desired arching of the lumbar area.

Side supports

Turn the knob **C** until the desired width of the side supports is reached.

Seatback tilting

Operate the lever **D** to tilt the backrest forward.

2 - About your vehicle

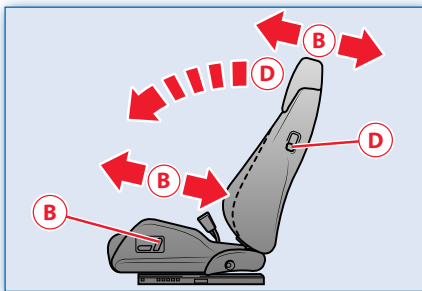

Adjusting the headrest

Move the headrest **E** until the desired height has been reached. Once the desired position has been found, the headrest can also be reclined forward and backward.

 Adjust the headrest to suit your height in such a way that the centre of the headrest is level with the nape and not the neck.

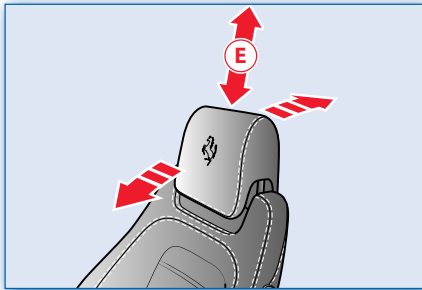

Heating System (optional)

The heating is activated by turning control **F**. Two heating pads are used to heat the seat. When this function is active for one or more seats, the relative warning light illuminates on the instrument panel.

Operating control **F** you can adjust the heating level, choosing from 3 levels identified on the control with the numbers 1, 2 and 3.

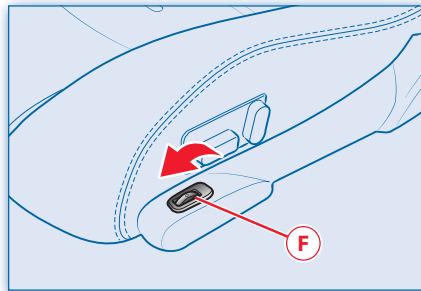

Interior rearview mirror

This can be adjusted manually.

To set the mirror in the anti-dazzle position, push the lever **A** forward.

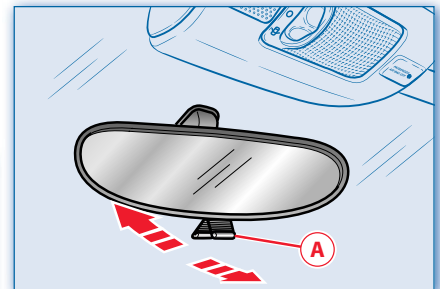

F430

Safety

FERRARI has designed and constructed a vehicle that offers the best possible performance for a road vehicle, guaranteeing the maximum in terms of safety. Following some simple rules will guarantee maximum efficiency of the entire system.

Passive safety

The passive safety system always intervenes in the event of a collision.

In addition to the seats and the headrests, the passive safety system components are:

- seat belts fitted with pretensioners and load limiting devices;
- airbag;
- manual passenger airbag deactivation switch;
- passenger airbag deactivation warning light;
- airbag system failure warning light (see [page 32](#));
- deformable bodyshell and protective survival cell;
- fuel cut-off inertia switch.

Depending on the impact, the passive safety system intervenes in different ways activating the various system components. In the event of small collisions: in addition to the protective action of the seats, headrest and bodywork of the vehicle, only the seat belts prevent the occupants from

being flung from the seat.

In the event of more severe head-on collisions (up to 30° angle): in addition to the seat belts, the pretensioners intervene with a restraining action.

In the event of an even more severe head-on collision up to a 30-degree angle with respect to the longitudinal axis of the vehicle: in addition to the pretensioners, the airbags intervene.

The load limiting devices on the seat belts provide a suitable restraining action for the occupant, so as to prevent serious injury to his/her chest.

 **The protective action of the airbags is always integrated with the seat belts and the pretensioners. If the seat belts are not fastened the driver and/or passenger may be seriously injured. In the event of collisions, side impacts or vehicle rollovers, i.e. when the airbags are not activated, it is essential to have the seat belts fastened.**

Deformable body

The deformable bodyshell absorbs shock and distributes it over the entire structure of the vehicle allowing progressive deceleration.

The passenger compartment structure, on the other hand, has been designed to offer maximum resistance without undergoing deformation, with the aim of ensuring a protective survival cell for the occupants.

Active safety

The active safety system has been designed to prevent collisions.

Apart from the manoeuvrability, stability and acceleration features of the vehicle, the active safety components are the following:

- braking system
- air conditioning and heating system
- external lights
- buzzer and warning lights (flashing).

The braking system comprises the mechanical brake system and the electronic traction stability control system (CST) which prevents the wheels from locking and always provides good manoeuvrability and stability.

The possibility of fast acceleration can in some cases get you out of dangerous situations. However, always use the accelerator with extreme caution. During acceleration of the driving wheels, the anti-skid system may help you in certain dangerous situations.

The air conditioning and heating system in the passenger compartment can add to driving comfort and keep you alert so that you can react quickly when necessary.

It is very important to see and be seen clearly, hence it is essential to turn on the external lights when the conditions so require.

2 - About your vehicle

Special warnings

This vehicle has been constructed in compliance with the strictest personal and environmental safety standards. Nevertheless, a few rules should be followed.

Particular attention must be paid to:

- Overheated components: high temperatures develop in the engine compartment in proximity of the exhaust system.
Do not park the car on paper, grass, dry leaves or other flammable materials. They could catch fire if they come into contact with hot parts of the exhaust system.
Do not fit other heat shields or remove those fitted on the exhaust system.
Do not let flammable substances come into contact with the exhaust system.
- Moving parts on the vehicle, such as fan belts etc. are always protected by appropriate systems.
Do not remove the guards or operate on the moving parts without taking the due precautions.
- Pressurised systems on the vehicle, such as: the braking system, air conditioning and heating system, cooling system and lubrication system, which may generate pressure internally.
Do not carry out any operation which may cause gas or liquids to spill out with

the risk of injury to persons and damage to things.

- The exhaust gas generated by the running engine may be hazardous, especially when in closed spaces. As well as consuming oxygen, the engine discharges carbon dioxide, carbon oxide and other toxic gases.
- The fuel is highly flammable and emits vapours which may be noxious if inhaled. Do not use naked flames or create sparks near the open fuel tank or in any other condition where fuel comes into contact with air.
- The oils used may also be flammable: take the same precautions as adopted for the fuel.
- The fluid contained in the battery is poisonous, corrosive and flammable. Do not let it spill out and come into contact with the skin, eyes or objects. Do not use naked flames or create sparks near the battery.

In any case, observe the various warnings contained in this manual.

Seat belts

If used correctly, the seat belts, in combination with the pretensioners and the load limiting devices, protect the occupants from all types of impact and firmly secure them to the vehicle structure, thus preventing dangerous jerks against the fixed parts of the passenger compartment.

 **FERRARI recommends you use the seat belts correctly fastened and adjusted at all times!**

Correct use of the seat belts can reduce the risk of serious injury in the event of an accident or if the vehicle overturns.

The standard seat belts are automatic, with 3 attachment points, and an emergency inertial locking winder fitted with pretensioner and load limiting device. For maximum protection, keep the backrest in the upright position, rest your back comfortably against it and adjust the seat belt in height so that it fits tightly across your chest and pelvis.

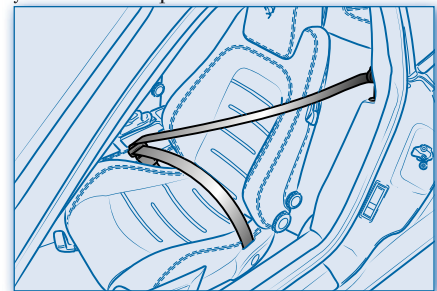

F430

Fastening the seat belts

After properly adjusting the seat and headrest:

- Grip the buckle **A**, slowly pull the belt and insert the belt tongue into the buckle **B** (if the belt locks while you are pulling it out, let it wind back briefly and pull it out again without jerking).
- Make sure that it has clicked into the locked position.
- Position the seat belt correctly.

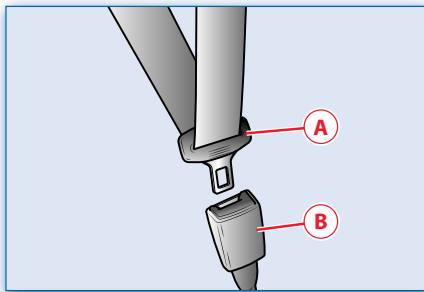

If the driver's seat belt is not fastened, when you turn the ignition key to position **II**, the warning light on the instrument panel illuminates and remains lit as long as the seat belt is not fastened.

60 seconds after a speed of 10 km/h (6.21 mph) is exceeded and up to 25 km/h (15.53 mph), a buzzer sounds to warn the driver that the seat belt is not fastened.

When the speed of 25 km/h (15.53 mph) is exceeded, the buzzer activates immediately

and stops after 90 seconds. This acoustic signal is emitted only once, even if the vehicle speed goes above and below the above mentioned limits. The acoustic signal is repeated (when the vehicle speed is in the indicated ranges) only if the seat belt is fastened and unfastened again or, in any case, every time the engine is turned off and then on.

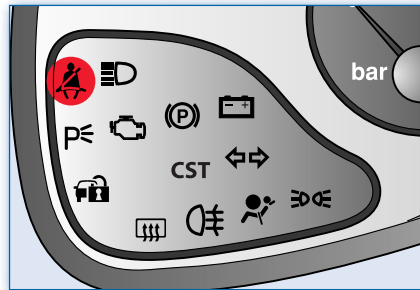

Do not use any devices (clips, catches, etc.) that hold the seat belt away from your body.

⚠ Do not allow a child to sit on the passenger's lap with both of them fastened with the passenger's seat belt.

Adjusting the seat belt in height

- Press button **D** to release the adjustment device and move it to the desired position.

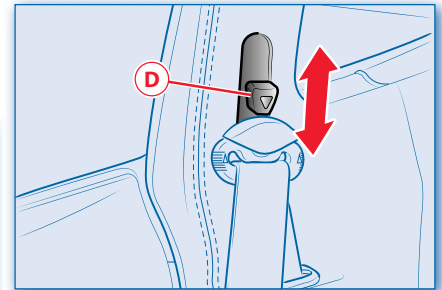

- Always check that it is locked. The seat belt is properly adjusted when it passes about mid-way between the end of the shoulder and the neck. The lower part must fit tightly across the pelvis and not the abdomen.

2 - About your vehicle

Unfastening the seat belts

- Push the release button **E**.
- Guide the belt hooking tongue **A** back to its rest position.

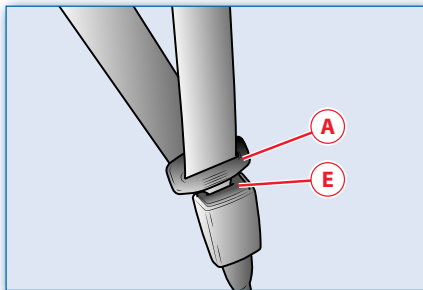

Load limiting devices

In the event of impacts at high speeds, with sharp deceleration, the load limiting device progressively releases the belt when the tension value reaches a predefined threshold. This action reduces the possibility of injury to the chest and shoulders of the occupant.

Pretensioners

The pretensioner is activated in the event of a violent head-on collision. The belt will rewind by a few centimetres a moment before the restraining action begins, thereby ensuring perfect tightness across the body.

Activation of the pretensioner is indicated by the relevant warning light on the instrument panel coming on and by the seat belt locking.



⚠ After activation, the pretensioner ceases to function and it cannot be repaired under any circumstances. Please contact the **FERRARI SERVICE NETWORK** to have it replaced.

When the pretensioner is activated, a small amount of powder is released. This powder is not harmful and does not indicate the start of a fire.

Maintenance of the seat belts and pretensioners

- Following a collision of a certain impact, replace the seat belts that were worn at the time even if they may not appear to be damaged.
- Periodically check that the screws on the anchoring points are tight and that the belt is intact and slides smoothly.
- The belt must be kept clean; any dirt on the belt could jeopardise the efficiency of the belt winder.
- To clean the seat belt, wash it by hand with mild soap and water and let it dry. Do not use strong detergents, bleach or aggressive solvents, as they can weaken the fibres.
- Do not let the belt winders get wet: proper functioning is guaranteed only if they are kept dry.
- The pretensioner requires no maintenance or lubrication.

If immersed in water or mud, the pretensioner must necessarily be replaced.

- The pretensioner must be replaced at the intervals specified in the "Warranty Booklet and Service Time Schedule".

⚠ All work on any part of the safety system components must be carried out by the **FERRARI SERVICE NETWORK**.

It is not permitted to remove or make modifications of any kind to the seat belts, belt winders and pretensioners.

Extraordinary maintenance work involving strong impact, vibrations or heating up of the pretensioner area may activate it; vibrations caused by road bumps will not have this effect.

Child safety

Because of their build, children are at greater risk than adults. Suitable restraint or safety systems must be used.

All minors whose physical characteristics (age, height, weight) fall within the limits laid down in the laws in force in each country must be protected by homologated restraint or safety systems (child seats, cradles, cushions).

In any case, you are advised to always use homologated child restraint systems bearing the test marking.

Always adjust the seat to the farthest backward position, in order to assure that the child is as far away as possible from the dashboard structure.

⚠ Incorrect fastening of a child restraint system increases the risk of injury to the child in the event of a collision.

- The seat belts in the vehicle have been designed and tested to protect persons weighing at least 36 kg (80 lb.) and taller than 1.50 m (4.9 feet).
- To hold a child not falling within these limits, specific restraint systems with dedicated belts or accessories able to adapt the child's position to the vehicle's

seatbelts must be fitted.

For installation and use of the child restraint systems, follow the instructions provided by the manufacturer of the devices.

⚠ On vehicles equipped with a passenger airbag deactivation device, do not fit a rearward-facing child seat on the passenger seat if the airbag is active, as the child risks serious injury or death in the case of airbag activation.

In this event, absolutely deactivate the passenger airbag using the dedicated control and check that the LED on the roof's ceiling light comes on (see page 57).

Also move the passenger seat as far back as possible in order to prevent the child seat knocking against the dashboard.

Do not tamper with the seat belts or child restraint systems.

⚠ Where provided for by the law (EC), children under the age of 3 may not travel in a vehicle if not sitting in a child restraint system.

⚠ Where provided for by the law (EC), children over the age of 3 and under 150 cm (4.9 feet) tall may not travel on the front passenger seat if not sitting in a suitable child restraint system.

The adhesive label applied on the right-hand side of the dashboard on vehicles not equipped with the passenger airbag deactivation device, indicates that it is

prohibited to fit a rearward-facing child seat on the passenger seat.

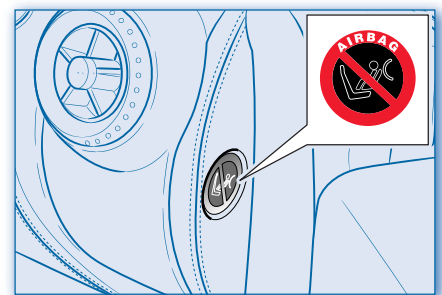

2 - About your vehicle

Airbag

⚠ The airbag is not a substitute for the seat belts but increases their effectiveness. Correct use of the seat belts in combination with the airbag offers maximum protection in the event of a head-on collision.

Airbag system components

The airbag system is composed of two instantly inflatable cushions, one situated on the driver's side **A** in the centre of the steering wheel and the other on the passenger's side **B** inside the dashboard.

⚠ When the ignition key is turned to position **II**, the relevant warning light on the instrument panel comes on and, if no faults are found, goes off after 4 seconds. If the warning light does not come on, or if it stays on, or if it comes on while driving, immediately contact the **FERRARI SERVICE NETWORK**.

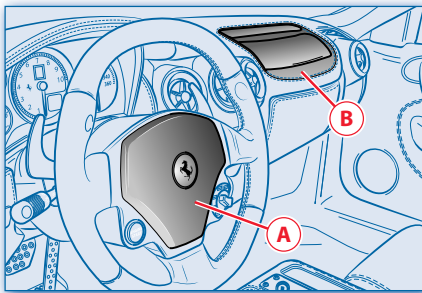

Operation

The airbags are controlled by a sensor and an ECU that activates them in the event of a head-on collision with medium or strong impact.

In the event that the impact is so strong that deceleration exceeds the sensor calibration value, the electronic control unit sends an airbag activation signal. The airbags start inflating, breaking the cover along the breaking line, until they are fully inflated in a few tenths of milliseconds and positioned as protection between the driver's or passenger's body and the structures which could cause injury.

The airbags deflate immediately afterwards.

⚠ The driver and passenger are both advised not to travel with objects (beverage cans or bottles, pipes, etc.) placed on the airbag module covers or near them, as they could be flung towards the occupants by the unfolding bag, with the risk of extremely hot gas leakages.

When the system starts operating, gases are released in the form of fumes together with the gas used for inflating the airbags.

These gases are not harmful.

⚠ Always drive with your hands on the crown of the steering wheel so that in case of activation, the airbag can inflate without obstruction.

Always keep the backrest in the upright position and sit with your back properly

resting against it.

The passenger must always fasten the seat belt and sit in an upright position, as far as possible away from the airbag, in order to have optimal protection in all types of collision.

Do not modify the system components or wiring under any circumstances.

Do not cut or tamper with the connectors linking the wiring and the airbag modules.

Do not cover the steering wheel and the padded panel on the dashboard on the passenger's side with adhesive tape or treat it in any way.

*Never remove the steering wheel; if necessary, have this done at the **FERRARI SERVICE NETWORK**.*

All the airbag system components must be replaced after an accident that has caused airbag activation.

*Following an accident not involving airbag activation, contact the **FERRARI SERVICE NETWORK** to have the system checked and any system components that may be damaged or malfunctioning replaced.*

⚠ Damaged or defective components of the airbag system cannot be repaired and must be replaced.

Improper operations on the system components may cause failures or undesired activation of the airbags with consequent damage.

The airbag system components have been

F430

specially designed for this specific vehicle model. Do not attempt to use them on other vehicles, as this could cause serious injuries to passengers in the event of an accident.

If the vehicle is to be scrapped, contact the FERRARI SERVICE NETWORK to have the airbag system deactivated.

If the vehicle has been stolen or there has been an attempted theft, have the airbag system checked by the FERRARI SERVICE NETWORK.

⚠ The airbag modules must be replaced at the intervals specified in the “Warranty Booklet and Service Time Schedule”, even if the vehicle has not been involved in a collision.

The plate located on the right-hand sun visor next to the courtesy mirror shows the expiry date of the airbag system. When this expiry date draws near, contact the **FERRARI SERVICE NETWORK** in order to have the system replaced.

The plates indicate the presence of the airbag system.

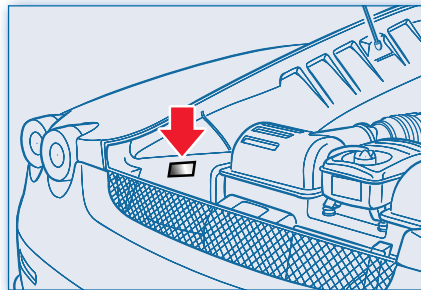
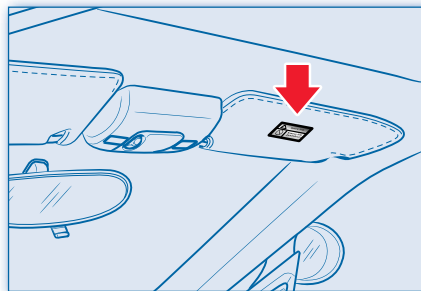
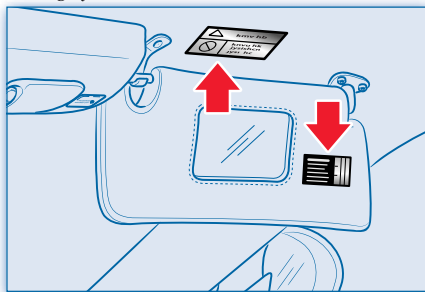

⚠ It is strictly prohibited to transport children in rearward-facing child seats if the passenger airbag is not deactivated. For passenger airbag deactivation on vehicles equipped with this device, see the next chapter.

On vehicles not equipped with the manual airbag deactivation system, children may not be transported in rearward-facing child seats fitted on the passenger seat.

Children under the age of 12 may not travel on the front seats.

Manual deactivation of the passenger-side airbag

If a child is to be transported in the front passenger seat, always deactivate the passenger-side airbag before fitting the child seat. The device is disabled by operating (with the ignition key) the relevant key switch located on the right-hand side of the dashboard.

The switch is accessible only with the door open.

The key switch has two positions:

- ON: passenger airbag active and LED on the roof's ceiling light off. It is strictly prohibited to fit a child seat and transport children on the passenger seat.
- OFF: passenger airbag deactivated and LED on the roof's ceiling light on; a child seat can be fitted and children can be transported on the passenger seat.

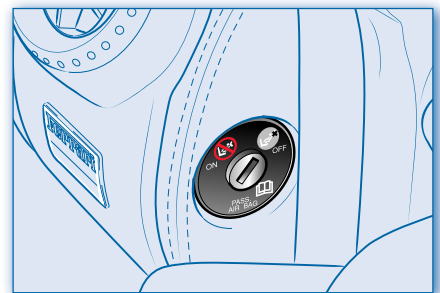

2 - About your vehicle

The LED remains on until the passenger airbag is reactivated.

When the passenger door is open, the key can be inserted or removed in both positions.

⚠ Deactivate the passenger airbag only when you need to transport a child in a child seat and reactivate it at the end of the journey. This way, the passenger sitting in the seat normally occupied by a child is protected by the airbag.

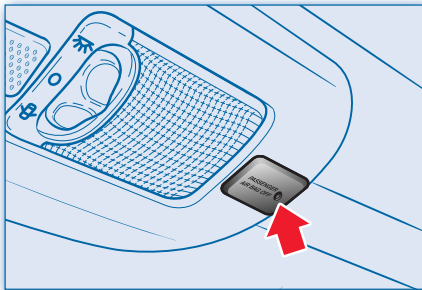

Passenger compartment accessories

Document compartment

Located on the dashboard on the passenger's side, it is always accessible with the key in position II.

To access the compartment, press button.

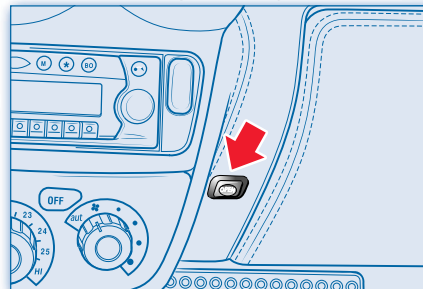

The compartment is illuminated by the ceiling light which comes on automatically when the lid is opened.

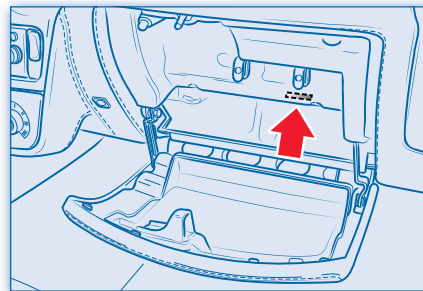

On the inside of the lid, there is a compartment containing the vehicle documents folder, and a torch for emergency use.

Keep the lid closed while driving.

To close the compartment, push the upper end of the lid until you hear the central side lock click.

Underneath the dashboard, on the outside right-hand side of the document compartment, there is a string for manual emergency opening of the compartment.

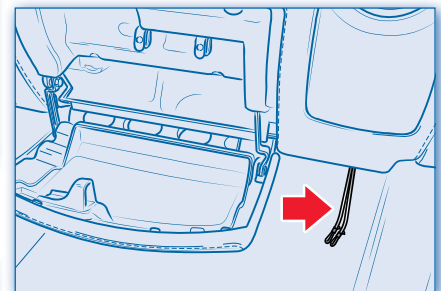

F430

Ashtray/Cigarette lighter

To gain access to the ashtray or to the cigarette lighter, lift the cover backwards.

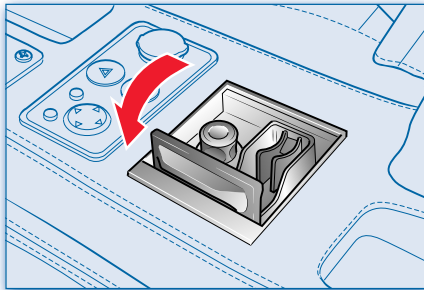

To clean the ashtray, extract it by pulling it upwards.

The cigarette lighter is turned on by pushing it fully in. After reaching the required temperature, the cigarette lighter is automatically snap-released to its initial position and is ready to be used.

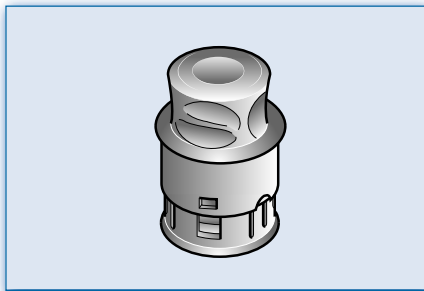

⚠ Do not use the cigarette lighter seat as a power socket for electrical devices, but use the dedicated socket only (see page 46).

The cigarette lighter reaches very high temperatures. Handle it with care to avoid risk of burns and fire.

Sun visors

The sun visors can be swivelled frontally by lowering them, and sideways by unhooking them from the catch and turning them towards the door window.

On the back of the driver-side visor there is a document pocket.

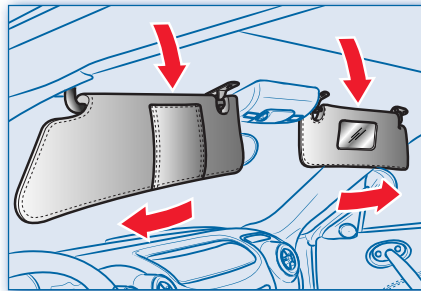

Courtesy mirror

On the back of the passenger-side visor there is a courtesy mirror.

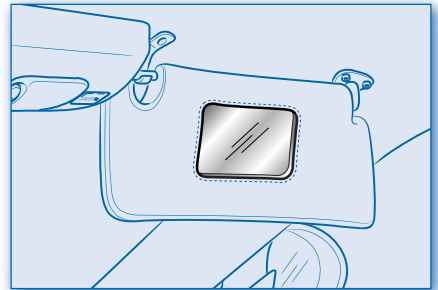

Pocket-change compartments

They are located on the lower side of the doors and on the central tunnel.

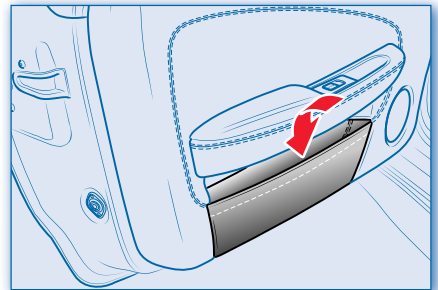

2 - About your vehicle

The pocket-change compartment on the front of the tunnel is only present on vehicles with F1 gearbox.

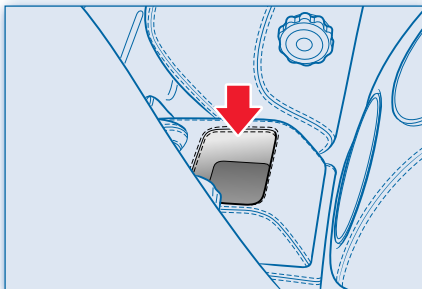
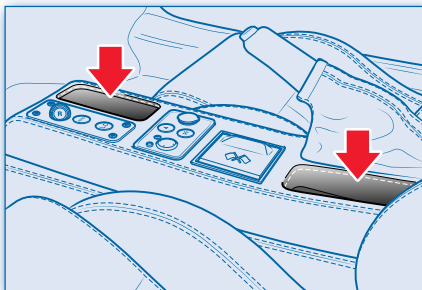

Two map pockets are fitted on the back of the seats to hold newspapers, magazines etc.

Do not put bulky and/or sharp objects in the map pockets as this may hinder seat positioning.

Internal lights

You can select when the ceiling light should come on with the switch on the roof:



on when the doors are closed.

off.

automatically on when the doors are unlocked for about 10 seconds, and when one of the doors is opened for about 3 minutes.

After closing the doors, the ceiling light remains on until the engine is started or in any case not longer than 20 seconds.

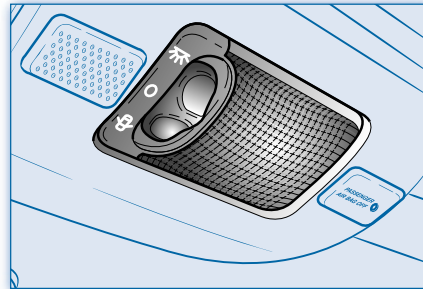

Hands-free microphone (optional)

The hands-free microphone is positioned on the roof, next to the ceiling light.

It is operational only in vehicles with Bluetooth™, supplied on request.

For further information on the device, consult the “Scaglietti Bodywork Programme” Owner’s manual.

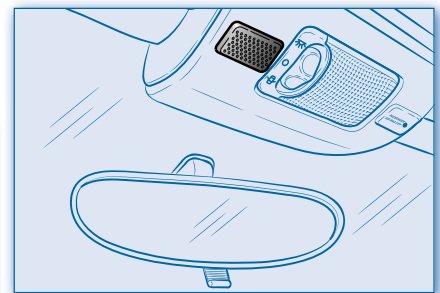

F430

Engine compartment lid

Opening

- Pull the release lever located on the door pillar, on the driver's side.

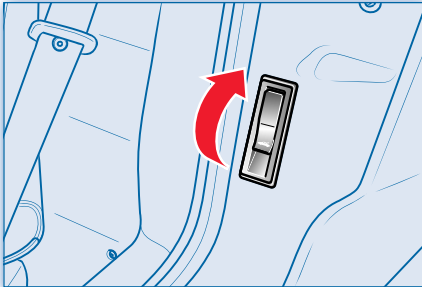

- Lift the engine compartment lid. The lid is held in position by two gas struts.

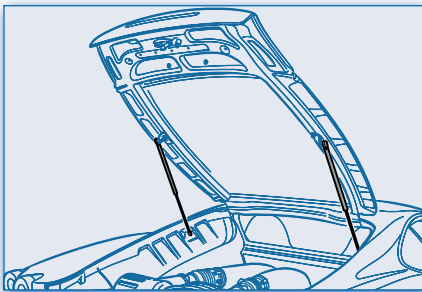

Closing

- Lower the lid until it is about 20 centimetres from closing, then let it drop.
- Always check that it is properly closed.

Emergency opening

If the opening lever malfunctions, pull the cable situated in the fuel filler cap compartment (see [page 37](#)).

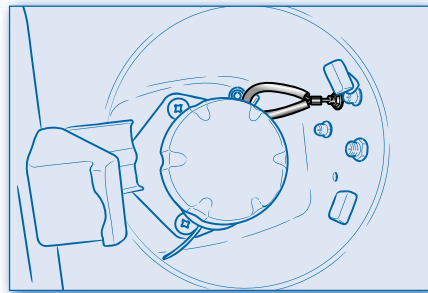

Air conditioning and heating system

- ① Fixed air vents for windscreen.
- ② Fixed air vents for side windows.
- ③ Adjustable central and side vents.
- ④ Air vents for foot area.
- ⑤ Sun radiation sensor.
- ⑥ Outside temperature sensor.
- ⑦ Passenger compartment temperature sensor.
- ⑧ Air conditioning and heating system controls.

The air conditioning and heating system allows the user to adjust the temperature and humidity in the passenger compartment.

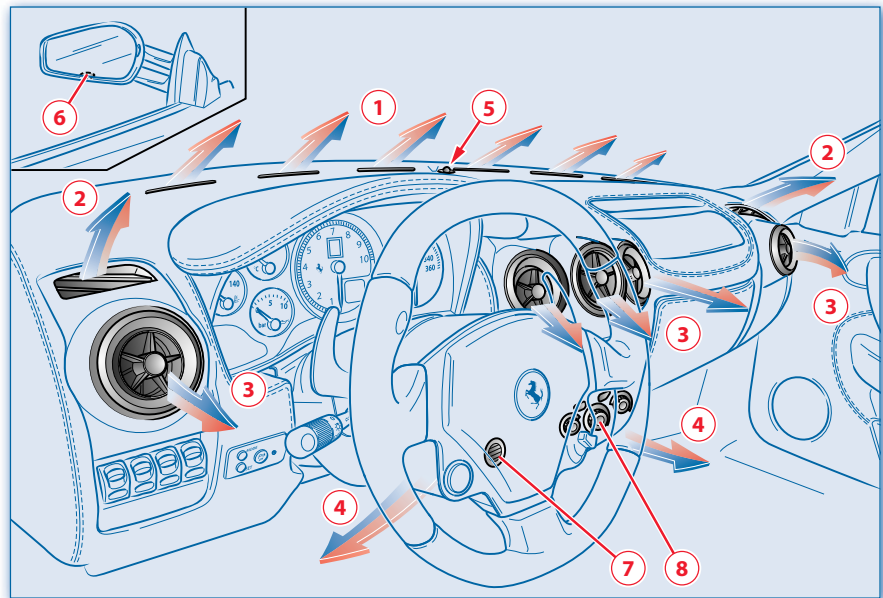

F430

Operating modes

Automatic

This mode automatically adjusts humidity and ventilation according to the selected temperature.

Manual

This mode allows adjusting the controls according to need.

Functions and controls

- ⑨ Air conditioning control switch.
- ⑩ Air distribution control.
- ⑪ Temperature selection control.
- ⑫ Fan speed control.
- ⑬ Air recirculation switch.

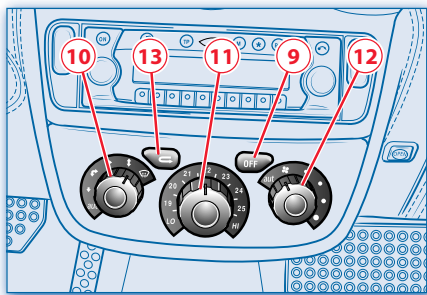

Air conditioning control switch

Released



The air conditioner is on.
The air is cooled and/or only dehumidified according to the selected temperature.

Pressed (stop)



The air conditioner is off.
However, heating is still enabled and will turn on according to the temperature set.

Air distribution control

It has three functions:

Automatic



The air flow distribution is controlled by the electronic system depending on the ambient conditions and the selected temperature.

Manual



The air flow is directed towards four different areas.

Fast demisting/defrosting



Activates demisting and/or defrosting of the windscreen and the side windows.

Temperature selection control



Used to set the desired temperature in the passenger compartment.

The end positions activate the functions **LO** and **HI** (minimum and maximum air temperature, respectively).

Fan speed control

It has two functions:

Automatic



The air flow is controlled by the electronic system according to the selected temperature to be reached and maintained.

Manual



The position (⊗) turns the air conditioning off and permits only intake of outside air when the vehicle is moving.



The four positions allow selecting the air flow rate.

Air recirculation switch

Released



The air flow comes from the outside.

When outside temperatures exceed 25°C, the air recirculation function remains on with a 1-minute pause every twenty minutes, to refresh the air.

Pressed (recirculation)



The air flow comes from inside the passenger compartment.

The recirculation speeds up air heating or cooling.

Prolonged use is unadvisable.

Once the interior temperature has stabilised at the desired level, you are advised not to change the position of the temperature selection switch unless the outside temperature changes drastically.

Changing the position of the temperature selection switch results in a certain difference between the temperature in the passenger compartment and the air flowing from the vents. This difference will gradually decrease as the system reaches the steady state.

Adjusting the air vents

A Air flow direction adjustment

B Air flow rate.

Turned anti-clockwise: open.

Turned clockwise: closed.

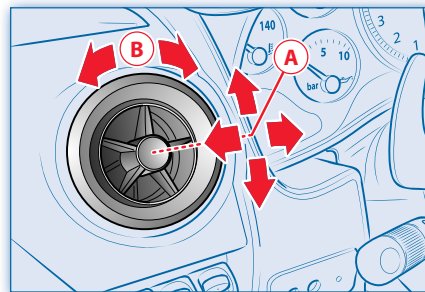

Maintenance

The pollen filter must be replaced every year as indicated in the "Service Time Schedule".

Sun radiation sensor

The sensor is positioned on the instrument panel and optimises ventilation and temperature control in the passenger compartment, depending on the incidence angle of the sun rays.

F430

64

3 - Driving your vehicle

Running-in _____	66
Before a trip _____	66
While driving _____	66
Starting and driving the vehicle (F1 gearbox) _____	67
Starting and driving the vehicle (Mechanical gearbox) _____	71
Parking _____	72
Safe driving _____	73
Respecting the environment _____	76
Parking manoeuvre _____	77



F430

Running-in

State-of-the-art production methods allow high precision in the construction and coupling of components. Nonetheless, the moving parts need to be bedded in, especially in the first hours of driving the vehicle.

Engine and transmission

Avoid exceeding 5000 rpm for the first 1000 km (620 mi.).

After starting, do not exceed 4000 rpm until the engine has warmed up sufficiently (water temperature: 65-70°C / 149-158 °F).

Do not let the engine run at a constantly high speed for a prolonged time.

Before a trip

Preliminary checks

Check the following at regular intervals and always before long trips:

- tyre pressure and conditions
- levels of fluids and lubricants
- state of the windscreen wiper blades
- proper functioning of the warning lights and external lights.

It is in any case advisable to carry out these checks at least every 800 km (500 mi.) and to always follow the "Service Time Schedule".

It is also advisable to:

- clean the glass covers of the external lights and all the glass surfaces;
- properly adjust the mirrors, steering wheel, seats and seat belts.

Capacities

 **Use unleaded fuel only!**
Using leaded fuel would irreparably damage the catalytic converters.

For lubricant and fluid specifications and amounts, follow the instructions given in the section "Recommended lubricants and fluids" in [page 14](#).

While driving

Always drive carefully and never exceed the maximum engine speed indicated by the red area on the revolution counter.

In normal conditions, all the red and amber light indicators for the suspension and CST systems on the multi-function display must be off. When on, these LEDs indicate a malfunction in the corresponding system. Ensure proper functioning of the various devices by checking the relevant control gauges.

 **Continuing to drive when a red warning light is on could cause serious damage to the vehicle and affect performance.**

After driving in SPORT or RACE mode, let the engine idle for several minutes before stopping it in order to stabilise the temperatures.

 **Do not freewheel downhill with the engine off, since the servo brake lacking vacuum does not function and after braking several times, the system loses nearly all its efficiency.**

3 - Driving your vehicle

Starting and driving the vehicle (F1 gearbox)

Switching on the system

When turning the ignition key to position **II** all the segments of the gear display on the instrument panel are activated and lit up, the failure warning light comes on and, if no faults are found, goes off after a few seconds.

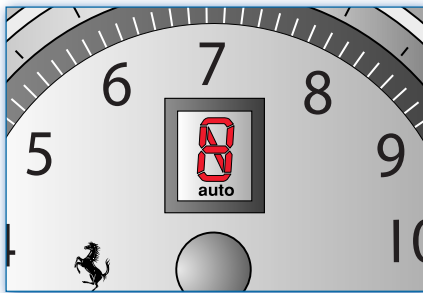

The gear currently engaged will remain highlighted on the display.

The pump may also start up for a few seconds when the driver's door is opened. This function makes it possible to have the system ready when the ignition key is inserted.

The failure warning light may also flash briefly (10 sec.) and then switch off: the system completes the "start-up" phase and then starts correctly. Avoid giving any commands to the system during this stage.

! If the failure warning light continues flashing without going off, switch off the system and restart. If the failure persists, contact an **AUTHORISED FERRARI SERVICE CENTRE** to have the necessary checks carried out.

If the warning light stays on, it means that there is a system failure; this condition will also have been signalled by a buzzer when the ignition key was turned to position **II**.

Contact the FERRARI SERVICE NETWORK to have the malfunction identified and repaired.

Operation with the engine switched off

Once the "system start-up" phase has been completed, the gear engaged will appear on the display:

- N** (Neutral)
- R** (reverse gear)
- 1** (1st gear)
- 2** (2nd gear), etc.

If the indication flashes (may also occur with **N**) it means that the gear is not perfectly engaged or disengaged; therefore, request **N** and then the desired gear.

! If a horizontal dash appears on the display, there is a system failure.

When the engine is off, you can engage the **1st**, reverse **R** and neutral **N** gears. Holding the brake pedal pushed down during the request, proceed as follows:

N: pull both the levers located behind the steering wheel.

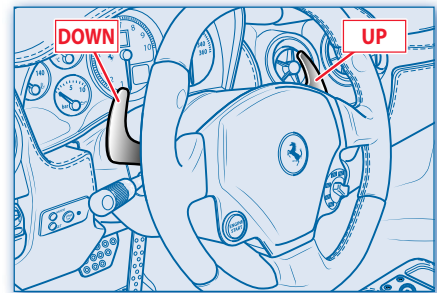

R: press button **R** on the central tunnel.

! Hold button **R** pressed down until the letter **R** appears on the display.

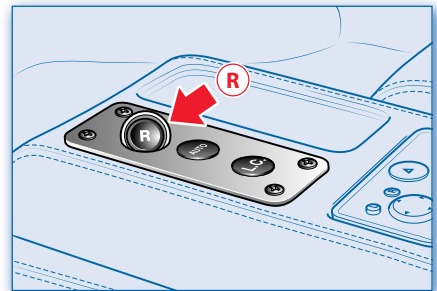

1st gear: pull the lever **UP** towards the steering wheel.

Release the **UP** and **DOWN** levers and the button **R** soon after the gear engaged is shown on the display; A prolonged manoeuvre would cause the failure warning light to come on (see page 32) and an acoustic signal to sound.

Do not operate the system with the engine switched off to prevent discharging the battery.

Avoid needless shifting of gears with the engine off to prevent overheating the pump.

If the engine compartment lid is open or not properly closed, no gear can be engaged.

When the vehicle is stationary with the driver-side door open or not properly closed and the brake pedal released, the system disengages the gear engaged after approximately two seconds.

Starting the engine

- Ensure that the handbrake is engaged and that the doors are closed.
- It is advisable to keep the brake pedal pressed when starting the engine.
- Do not push the accelerator pedal.
- Turn the key to position **II** and wait for the wording **CHECK OK** to appear on the multi-function display. If the wording **CHECK OK** does not appear, turn the key back to position **0**, wait a few seconds and retry.
- Put the gearshift in neutral by pulling both the **UP** and **DOWN** levers towards the steering wheel and check that the gear display shows **N** not flashing.

- Press the **ENGINE START** button and release it as soon as the engine starts.



- After the engine has started, the words **CHECK OK** appear.

Do not hold the **ENGINE START** button pressed down for a long time.

If the engine does not start, turn the key back to position **0** and wait for the gear display to go off before retrying.

⚠ Hold the brake pedal pushed down when starting the engine.

The engine can also be started with a gear engaged; turn the key to position **II**, hold the brake pedal pushed down and press the **ENGINE START** button. The system allows the clutch to open and the gear to shift to neutral and then the starter motor is given clearance to start the engine. This procedure usually requires one second. With very low temperatures, this procedure could take slightly longer.

If the gearshift is in position **N**, starting is

immediate.

If the engine does not start after turning the key to position **0**, wait for the gear display to go off and then repeat the entire procedure.

If the engine fails to start after several attempts, check for one of the following causes:

- insufficient starter motor speed (flat battery)
- ignition device faulty
- faulty electrical contacts
- fuel pump fuses blown.

Warming up the engine

Do not run the engine at high speeds until the engine oil temperature has reached at least 65-70°C (149-158 °F).

Driving the vehicle

With the engine started, the vehicle standing and the brake pedal pushed, pull the right-hand **UP** lever towards the steering wheel in order to engage the **1st** gear.

⚠ Use 1st gear for parking or uphill starting.

Release the brake pedal and push the accelerator to start off.

With the engine on and the vehicle standing, you can change directly from **1st** gear to **R** by pressing the button **R** on the central tunnel, and from reverse to **1st** gear

3 - Driving your vehicle

by pulling the **UP** lever towards the steering wheel.

*When the reverse gear is engaged, an acoustic safety signal beeps intermittently for the entire time that **R** remains engaged.*

If in shifting from **R** to **1st** gear, the system automatically engages the **2nd** gear, which means that the **1st** gear has jammed. This is not a malfunction, but part of the system operating logic. For the same reason, when shifting from **1st** gear to **R**, the system will automatically engage **N** if the gear is jammed.

If the vehicle stands still for long periods of time with the engine running, it is advisable to keep the gearshift in **N**.

*If you allow the vehicle to move forward in **N** (e.g. on downhill stretches), when **UP** is requested, the system will engage a gear in relation to the vehicle speed.*

For safety reasons, the system activates the buzzer and automatically shifts to **N** when you do any of the following with the vehicle standing, the engine running and a gear engaged:

- not push the brake pedal or the accelerator for more than 50 seconds;
- push the brake pedal for more than 10 minutes;
- open the door without pushing the brake pedal or the accelerator;
- open the engine compartment lid.



The buzzer may also sound to warn the driver that the clutch is starting to overheat. This may occur when using the accelerator pedal when the vehicle is stopped uphill or during the “pick-up” manoeuvre.

In these cases, release the accelerator pedal and use only the brake pedal to stop the vehicle or, where possible, “force” it to move without hesitation.

Important

- When the vehicle is standing with a gear engaged, always hold the brake pedal pushed down until you are ready to leave.
- Do not “rev the engine” using the accelerator pedal when you start off.
- Request reverse only when the vehicle has completely stopped and with the brake pedal pushed down.

If the vehicle is stopped on an uphill stretch, do not use the “pick-up manoeuvre” to keep the vehicle stationary but only the brake, and push the accelerator pedal only when you are ready to leave.

If the accelerator pedal is fully depressed very fast with the **CST** system off, the vehicle will do a “performance” start with considerable skidding of the driving wheels, even in good grip conditions.

Upshifting

Operate the right-hand **UP** lever without releasing the accelerator pedal.

An **upshift** request is not accepted when engagement of the requested gear will force the engine to run at a too slow speed or if an **upshift** is already in progress due to a runaway speed rate.

Gearshifting will be increasingly faster as the performance requested by the driver increases, i.e. as both the engine rpm and the travel of the accelerator pedal increase.

In any event, it is advisable to:

- Shift gears without releasing the accelerator pedal.
- Wait until one gearshift has been completed before requesting the next one, thereby avoiding multiple requests in rapid succession.

Downshifting

Operate the left-hand **DOWN** lever without releasing the accelerator pedal.

A **downshift** request is not accepted if engagement of the requested gear will force the engine beyond a certain speed, depending on the gear requested, or if a **downshift** is already in progress due to a too low engine rpm.

In any case, it is best to:

- Shift gears without releasing the accelerator pedal.
- If a **downshift** is requested in order to start overtaking where rapid acceleration is required, push the accelerator pedal just before moving the lever.

F430

- Wait until one gearshift has been completed before requesting the next one, thereby avoiding multiple requests in rapid succession.

RPM adjustment during gearshifting

Under racing-style driving conditions (engine over 3000 rpm.) and even more markedly as engine speed increases, r.p.m. rate is adjusted automatically during gearshifting.

N (Neutral) request

If necessary, N can be requested at any speed.

Subsequently, if an **upshift** is requested, the system will engage the gear most suited to the speed of the vehicle.

Stopping the vehicle

When the vehicle stops, the system automatically engages the **1st** gear (unless N has been requested before).

With the vehicle standing and the engine running, hold the brake pedal pushed down until you are ready to start off again.

Switching off the engine and the system

The engine can be switched off either with the gearshift in N or a gear engaged.

After turning the ignition key from position **II** to position **O**, the display will remain on for a few more seconds to indicate which gear is engaged. If the gearshift is in N, a buzzer will sound.

 Do not start the vehicle before the display has switched off.

Never leave the vehicle with the gearshift in N but engage a gear (**1st** or **R**), check that the display does not flash and always engage the handbrake. Never leave the vehicle with the engine running.

Do not remove the key when the vehicle is moving! The system and hence the display will remain active but malfunctioning until the vehicle stops. In addition, the steering wheel will lock automatically the first time the steering wheel is turned.

In this case, the failure warning light will come on (see page 32) and before starting off again, the system, and hence the display, must be switched off and the “start-up” procedure repeated.

In any case, it is best to:

- Switch off the engine and the system holding the brake pedal pushed down.
- Do not request a gearshift while the system is switching off.

Other system functions

“Automatic gearshift” mode

This mode is activated by pressing the **AUTO** button on the central tunnel.

Activation is signalled by the word **auto** appearing on the gear display, on the instrument panel.

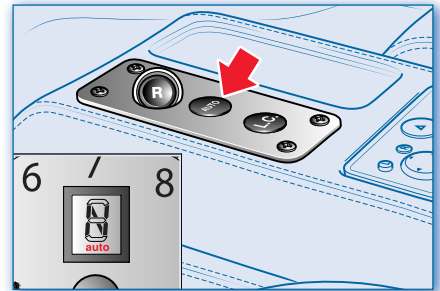

The system will automatically shift the gears **UP** and **DOWN** according to the vehicle speed, the engine rpm and the torque/power requested by the driver.

When the vehicle is stopped, a N, **1st** gear or **R** request will not result in a change from “Automatic” to “Normal”.

The “Automatic Gearshift” mode can only be exited by operating the **AUTO** control button.

In the “Automatic” mode, if you operate the **UP** and **DOWN** levers, the system allows shifting gears using the lever, but it will then go back to the “Automatic” mode.

3 - Driving your vehicle

“Launch Control” strategy for performance starting

With the aim of optimising standing starts, in performance conditions, the F1 gearbox system F1 is equipped with a “launch control” system, which is activated when the following conditions occur simultaneously:

- 1st gear engaged
- brake pedal pushed
- ~~CST~~ mode activated
- L.C. button pressed.

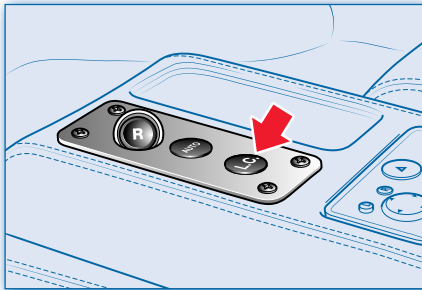

In these conditions, a **L** will flash on the gear display. Accelerate holding the brake pedal pushed down until the desired engine speed for the standing start has been reached (typically the maximum torque speed). On releasing the brake pedal, the best standing start performance is achieved thanks to a clutch engagement strategy optimised for that engine speed.

Push start

In the event that the ignition system malfunctions, you can “push start” the vehicle as follows:

- Run the “system start-up” procedure (see [page 67](#));
- As the vehicle picks up speed, request an **UPshift** with the gearshift in **N**.

This procedure should be avoided unless there is an emergency situation!

Restarting the engine

In the event that the engine is turned off accidentally, restart it using the relevant button (see [page 68](#)) turning the key to **0** and then to **II** (On): the engine will start immediately.

Starting and driving the vehicle (Mechanical gearbox)

Starting the engine

Before starting the engine, make sure that the alarm system and all electrical devices with high power absorption are turned off.

- Check that the handbrake is engaged.
- Put the gearshift lever into neutral.

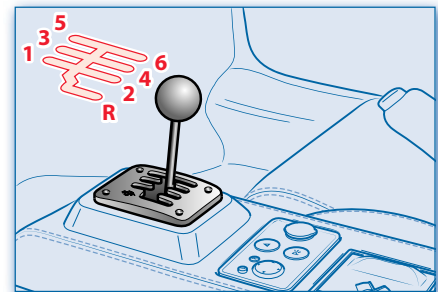

- Fully depress the clutch pedal without pushing the accelerator.
- Turn the key to position **II**: and wait for the wording **CHECK OK** to appear on the multi-function display.
- Press the **ENGINE START** button and release it as soon as the engine starts. Do not hold the **ENGINE START** button pressed down for a long time.

F430

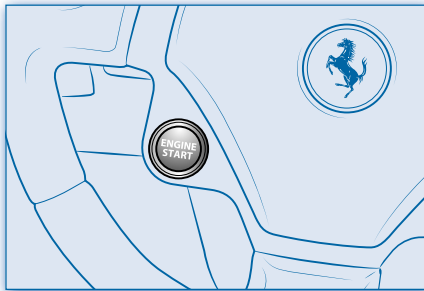

If the engine does not start, turn the key back to position 0 before repeating the procedure.

- After the engine has been started, the words **Check OK** will appear. If the words **Check OK** do not appear, turn the key back to position 0, wait a few seconds and retry.

If the engine fails to start after several attempts, check for one of the following causes:

- insufficient speed of the starting motor (flat battery);
- ignition device faulty;
- faulty electrical contacts;
- burnt fuel pump fuses.

Warming up the engine

Do not run the engine at speeds higher than 4000 rpm until the engine oil temperature has reached at least 65-70°C.

Driving the vehicle

When the engine has started:

- Fully depress the clutch pedal and put the gearshift lever into 1st gear.

 **Use the 1st gear for parking and for hill starts.**

- Completely release the handbrake.
- Slowly release the clutch pedal while gradually accelerating.
- Then proceed to engage the other gears, fully depressing the clutch pedal and moving the gearshift lever into the next position. When shifting down, be careful not to exceed the maximum permitted engine rpm (indicated on the rev counter in the area with red notches).
- Engage reverse gear only with the car stationary: Push the gearshift lever down and then move it left and back.

Parking

Engage the handbrake, put the gearshift lever into 1st whether parking uphill or downhill, steer the wheels and switch off the engine (valid for all versions, both with mechanical and F1 gearbox).

As the 1st gear is the most reduced, it is more suited to use the engine as a brake.

When parking on a steep slope, use a wedge or rock to block the wheels.

Never leave the ignition key in position II.

Always remove the key when getting out of the vehicle.

 **Never leave children unattended in the vehicle.**

Do not park the vehicle on flammable materials (paper, grass, dry leaves, etc.). They could catch fire if they come into contact with hot parts of the exhaust system.

Do not leave the engine running with the vehicle unattended.

3 - Driving your vehicle

Safe driving

For safe travelling, it is essential that the driver be aware of the best driving techniques suited to various circumstances. To help the driver safely handle stretches with different grip conditions, without excessively reducing driving performance and pleasure, the five-position switch on the steering wheel can be used to select the best position/setting of the vehicle in any condition (see [page 76](#)).

Always try to prevent dangerous situations by driving with caution.

Before you drive

- Adjust the position of the seat, steering wheel and rear view mirrors, in order to obtain the best driving position.
- Adjust the backrest so that the chest is upright and the head as close to the headrest as possible.
- Carefully adjust the headrest so that the head, and not the neck, is resting against it. Ensure that nothing (mat covers, etc.) is blocking the pedals.
- Check that the lights and headlights are working properly.
- Check proper functioning of the acoustic and visual warning devices.
- Ensure that any child restraint systems (child car seats, etc.) are properly fixed on the passenger seat.
- To prevent objects being thrown

forwards in the event of sudden braking, place them in the luggage compartment.

- Your reflexes are quicker if you eat lightly before driving: avoid heavy meals before a trip.
- Do not drink alcoholic drinks before and during the journey.
- Check that the switch is positioned on the desired driving mode.

 **If the vehicle was previously used in RACE or ~~CS1~~ mode, the RACE mode will still be active upon new starting and this might be dangerous in the event of poor grip conditions.**

Always fasten the seat belts and adjust them properly. Correct use of the seat belts can considerably reduce the risk of serious injury in the event of an accident.

At regular intervals, check the following:

- Tyre inflation pressure and condition
- Engine oil level
- Engine coolant level and cooling system condition
- Brake fluid level
- Hydraulic steering system fluid level
- Windscreen washer fluid level.

When travelling

- Caution is the number one rule for safe driving, which also means ensuring you can anticipate other people's incorrect or imprudent behaviour.
- Follow the Road Regulations of the country in which you are driving, and always respect the speed limit.
- Strictly comply with the road signs and road regulations (both national and local) of the country in which you are driving.
- Always check that you and the passenger have your seat belts fastened; children must be seated in the required child seat in vehicles equipped with the device for manual deactivation of the passenger airbag.
- Good physical fitness will allow you to safely travel long distances. In any case, take regular breaks to loosen up your limbs and refresh yourself, and avoid driving for hours on end.

Drunk driving, or driving under the influence of drugs or certain medicines is extremely dangerous for yourself and others.

Taking certain medicines, alcohol, drugs or psychotropic substances is extremely dangerous for yourself and others as it considerably increases the risk of accidents. Travelling without your seat belt fastened increases the risk of serious injury and

death in the event of a collision. Always fasten the seat belts, including those of the child seat.

Deactivate the passenger airbag (where possible) if transporting a child in a child seat fixed on the passenger seat.

It is strictly prohibited to fit a child seat and transport children in vehicles not fitted with the device for manual deactivation of the passenger airbag.

Do not travel with objects lying around on the floor, especially in front of the driver's seat: in the event of braking, these could slide under the pedals, making it impossible to brake or accelerate. In this connection, ensure that any loose covering mats sit perfectly.

Water, ice and salt spread to combat icy roads may deposit on the brake discs and reduce the efficiency of the initial braking.

- Keep a constant air circulation in the passenger compartment.
- Never drive downhill in neutral with the engine off: in these conditions the engine brake, the power steering and the brake servo do not work and hence steering will be harder.

Driving at night

When you are travelling at night, follow these fundamental rules:

- Reduce speed, particularly on unlit roads.
- Driving conditions are more demanding at night, so take particular care.
- If you start feeling tired or sleepy, stop immediately: to continue driving would be a risk for yourself and for others. Resume your journey only after a good rest.
- At night, it is difficult to judge the speed of vehicles in front of you as you can only see their taillights: keep at a greater safety distance than you would during the day.
- Use the high beams only outside of densely-populated areas and when you are sure that they will not disturb other drivers.
- Switch off the high beams when you see oncoming vehicles and use the low beams.
- Keep the taillights and headlights clean.
- Watch out for animals crossing the road when travelling outside built-up areas.

Driving in the rain

Rain and wet roads can cause hazardous situations.

All manoeuvres are more difficult on a wet road as the tyres have significantly less grip on the asphalt. This means that the braking distances increase considerably and road-holding lessens.

Below is some advice for driving in the rain:

- Position the selector on the steering wheel on "Low Grip" mode.
- Keep a greater safety distance between yourself and the other vehicles and reduce your speed.
- When it is raining very hard, visibility is also reduced. In these cases, to make yourself more visible to others, switch on the low beams even during the day.
- Do not drive through puddles at high speeds as you do not know how deep they may be: travelling through a puddle at high speed can result in losing control of the vehicle (aquaplaning): Hold the steering wheel firmly.
- Activate the ventilation controls to demist (see [page 62](#)) and prevent visibility problems.
- Periodically check the conditions of the windscreen wiper blades.

3 - Driving your vehicle

Driving in fog

- Whenever possible, avoid setting off if the fog is thick. If you have to drive in misty conditions, or if there is thick fog or fog banks, follow these rules:
 - Position the selector on the steering wheel on "Low Grip" mode.
 - Keep a moderate speed.
 - Switch on the low beams, even during the day, and use the rear and front fog lights. Avoid using the high beams.
- On stretches where visibility is good, switch off the rear fog lights as they are very bright and may be annoying for the occupants of the vehicles behind you.
- Remember that fog makes the road damp and therefore all manoeuvres are more difficult and, what is more, braking distances become longer.
 - Considerably increase the safety distance to the vehicle in front of you.
 - As far as possible, avoid suddenly changing speed and direction.
 - As far as possible, avoid overtaking.
 - Pull off the road and stop only if strictly necessary (because of a breakdown or if you cannot continue owing to poor visibility). Then turn on the hazard lights and, if possible, the low beams. On approaching another vehicle, sound the horn rhythmically.

Driving on mountain roads

- Position the selector on the steering wheel on "Low Grip" or SPORT mode, depending on the grip conditions.
 - To prevent the brakes from overheating when driving downhill, use the engine to brake by engaging a lower gear.
 - Never freewheel downhill in neutral or with the engine off, let alone with the ignition key removed from the steering column.
 - Drive at a moderate speed and do not "cut" corners.
 - Remember that overtaking uphill is slower and thus requires a longer free stretch. If you are overtaken when driving uphill, ensure that the other vehicle can pass easily.
- ### *Driving on snowy or icy roads*
- Below is some advice for driving in these conditions:
- Position the selector on the steering wheel on ICE mode.
 - Keep a very moderate speed.
 - Keep an ample safe distance from the vehicles in front of you.
 - Fit snow tyres approved for the vehicle.
 - Given the poor grip, use the engine brake as much as possible and avoid sudden braking.
 - Avoid sudden acceleration and sharp changes in direction.

- During the winter season, even apparently dry roads can have icy sections. Hence, be careful when driving along stretches of road in the shade as there may be icy patches.

Driving with the ABS braking system

The ABS system provides the following advantages:

- It prevents the wheels from locking and skidding during emergency braking, particularly in low-grip conditions
- It allows braking and changing direction at the same time, compatibly with the physical limits of lateral grip of the tyre.
- When the ABS is activated, you will feel a slight pulsing of the brake pedal during emergency braking or in low-grip conditions. Do not release the pedal but continue to push it to give continuity to the braking action.
- The ABS prevents the wheels from locking, but it does not increase the physical limits of grip between the tyres and the road: keep a safe distance from the vehicles ahead and reduce speed before curves.

F430

Driving using the driving mode switch

The driving mode switch on the steering wheel allows the driver to use the vehicle potential in a fast and intuitive way.

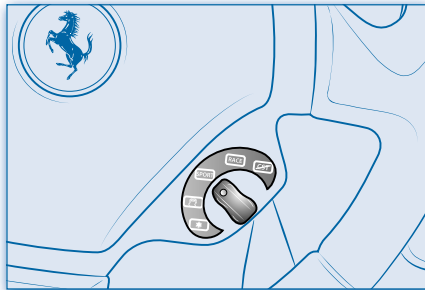

There are five modes available, which correspond to the grip level (from low to high) and consequently to the level of driving assistance required (from high to none).

ICE In the **ICE** mode, performance is reduced in favour of maximum stability, which is essential for driving on roadways with very low grip (snow or ice). Traction stability control (CST) is at the maximum level (Level 1). The vehicle runs extremely “smoothly”. On vehicles equipped with F1 gearbox, gearshifting is automatic at high engine speeds, and wheel locking is inhibited in the event of downshifting on icy roadways.

Low Grip The “**Low Grip**” mode ensures stability on both dry and wet roadways.

It is advisable to use this mode in low-grip conditions (rain) or on slippery or particularly uneven roads. In this configuration, unlike the previous one, the driver is left the choice to drive the vehicle using the gearbox as desired. Suspension damping is optimised in order to provide the best possible driving comfort and the **CST** remains set to the previous level.

SPORT The **SPORT** mode is the basic driving mode for the vehicle and provides the best compromise between stability and performance. This position ensures stability only in medium- to high-grip conditions and not in low-grip conditions (in which case it would be better to return to the previous position). In this mode, the vehicle maximum performance can be experienced on roads open to traffic. For this reason, the suspension damping level is shifted to a higher one, so as to enhance performance, handling and stability at high speeds. Also the **CST** is shifted to a different level (Level 2), giving the driver greater freedom without excessively reducing engine performance (for this reason, stability is not ensured on low-grip roadways).

RACE The **RACE** mode is to be used exclusively on the race track. On vehicles equipped with F1 gearbox, gearshifting is faster so as to reduce the time involved as much as possible. The **CST** shifts to Level 3 (engine load will only be limited as far as necessary) and the suspensions

stiffen further. In this position, the driver can perceive that he has full control of the vehicle, and the operation of all engine control systems will be reduced to a minimum. Stability is not ensured.

CST This is the position where the **CST** is deactivated. The vehicle stability is no longer controlled in any way, but it is completely in the hands of the driver. The only auxiliary systems still active are those that cannot be deactivated, such as the ABS and EBD. Also in this position, the electronic differential has a specific setting, which enhances the dynamic qualities of the vehicle in the absence of stability controls. The gearshift speed (on vehicles with F1 gearbox) and the damping control remain the same as in the previous position.

Respecting the environment

We are all responsible for respecting and protecting the environment.

FERRARI has designed and constructed a vehicle using technologies, materials and devices such as to reduce the harmful impact on the environment to a minimum.

It is important to keep the vehicle perfectly efficient by complying with the “Service Time Schedule”.

As further contribution towards protecting the environment, drive safely and behave responsibly at all times.

3 - Driving your vehicle

Parking manoeuvre

To assist the driver during parking manoeuvres, the vehicle can come equipped with four sensors housed in the front and rear bumper.

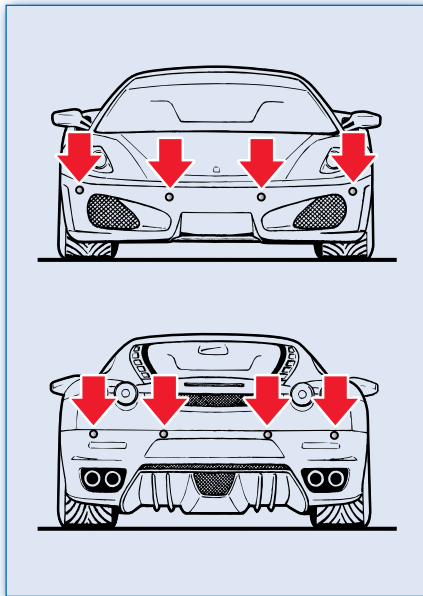

⚠ For the system to operate correctly, the sensors positioned on the bumpers must be kept clean (remove any mud, dirt, snow or ice).

During parking manoeuvres, the sensors provide the driver with information on the distance between the vehicle and obstacles found in front of or behind it.

The information on the presence and distance of the obstacle is given to the driver by means of a series of beeps, which are emitted with increasing frequency as the obstacle gets closer.

The acoustic warning generated by the system adds to the driver's field of vision, allowing him/her to avoid hitting any obstacles during manoeuvres.

⚠ The driver is in any case always responsible for parking and other potentially dangerous manoeuvres. The system has in fact been designed only as aid during parking manoeuvres, since it allows the driver to detect obstacles outside his/her field of vision.

The front and rear sensors of the parking system are automatically activated when the key is turned to position II (On), when reversing.

When reverse gear is engaged, a beep warns the driver that the system is active.

The front sensors can be activated by pressing the button on the panel to the left of the steering wheel; when the front sensors are activated, the LED integrated in the button turns on. To deactivate the sensors, press the button again.

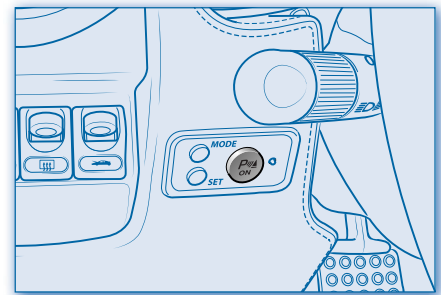

When reverse gear is disengaged, the rear sensors are deactivated while the front sensors remain active until a speed of about 15 km/h is exceeded.

When the sensors are activated, the system begins to beep as soon as an obstacle is detected and the beep frequency increases as the obstacle gets closer.

When the obstacle is at a distance of less than 40 cm from the bumper, a continuous beep is emitted.

The warning beep stops immediately if the distance between the vehicle and the obstacle increases.

Cleaning the sensors

When cleaning the sensors, take the utmost care not to scratch or damage them; therefore, do not use dry, rough or hard cloths. The sensors must be washed with clean water, possibly with car shampoo added. In car-washes which use steam jet or high pressure cleaning machines, keep the nozzle at least 10 cm away from the sensors. Bumper repainting or touching up the paintwork in the sensor areas may exclusively be carried out by the **FERRARI SERVICE NETWORK**. Incorrect paint application could affect the parking sensor operation.

Sensor range

The sensors allow the system to monitor the front and rear of the vehicle; in fact, they are positioned so as to cover the central and lateral areas at the front and rear of the vehicle.

In the event of an obstacle located in a central area, it will be detected at distances of less than 1.50 m, depending on the type of obstacle and its dimensions.

If the obstacle is located in a lateral position, it will be detected at distances of less than 0.8 m.

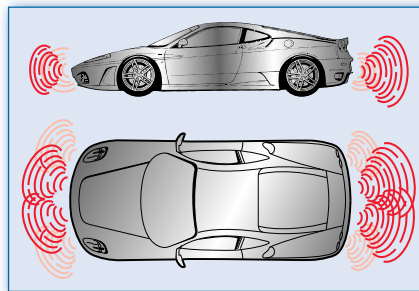

Fault signals

The system ECU tests all the components each time the ignition key is turned to position **II**.

The sensors and the respective electrical connections are then constantly checked throughout system operation.

In the event of failure of the parking sensor system, the driver is warned with a beep.

In this case, stop the vehicle and turn the ignition key to position **0** (Stop). Then try cleaning the sensors or moving the vehicle away from any possible ultrasound sources (e.g. pneumatic truck brakes or pneumatic hammers) and turn the ignition key back to position **II**. In this way, if the cause of the operating fault has been corrected, the system resumes full operation and the warning beep goes off.

Should this not occur, contact the **FERRARI SERVICE NETWORK** to have the system checked even if it continues working. In fact, if the failure detected by the ECU does not affect operation, the system continues working and the malfunction is stored so that it can be checked by the **FERRARI SERVICE NETWORK** during a subsequent inspection.

During parking manoeuvres, always be extremely careful with obstacles that might be located above or below the sensors. In particular, low-lying (e.g. curbs, stone posts), broken (e.g. wire mesh fences, hedges), thin (e.g. poles, lampposts) or suspended obstacles (e.g. bars/overhead doors) may in certain conditions not be detected by the system and hence damage the vehicle or the obstacles.

The signals transmitted by the sensors can also be altered by damage to the sensors or by dirt, snow or ice on the sensors or even by ultrasound systems (e.g. pneumatic truck brakes or pneumatic hammers) in the vicinity.



The driver is in any case always responsible for parking and other potentially dangerous manoeuvres. During these manoeuvres, always make sure that there are no persons (especially children) or animals in the manoeuvring area. The parking sensors must be considered as an aid to the driver who, in any case, must never take less care during potentially dangerous manoeuvres, even if they are performed at low speeds.

4 - In an emergency

Toolkit _____	80
Replacing the wheels _____	82
Replacing a bulb _____	84
Bulbs _____	88
Replacing a fuse _____	88
Emergency ignition _____	94
Towing the vehicle _____	95
Fuel cut-off inertia switch _____	96



F430

Toolkit

Toolkit bag

This is housed in the luggage compartment.

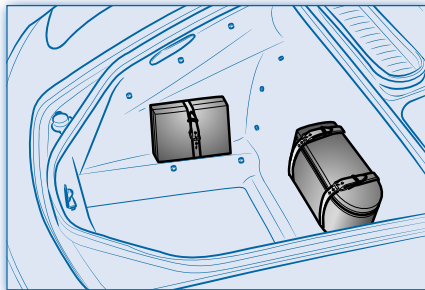

It contains the necessary tools to allow you to make a first repair in the event of a failure:

- set of flat wrenches
- insulated cutting pliers
- screwdriver for cross-head/slotted screws
- tow hook
- set of spare bulbs and fuses.

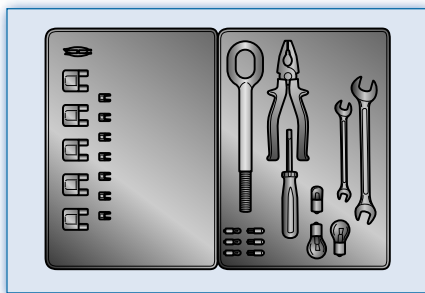

Emergency tyre repair and inflation kit

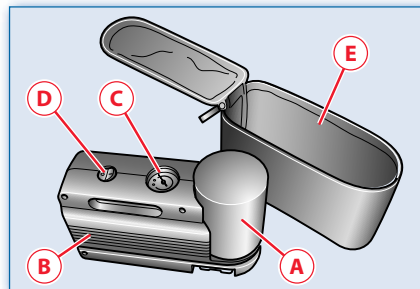

In the event of a puncture or low pressure of a tyre, the kit can be used to repair and/or inflate the tyre sufficiently to continue the journey safely.

The kit includes a replaceable cartridge **A** containing the puncture repair fluid, an electric compressor **B** equipped with a pressure gauge **C**, a switch **D** and two unions for tyre repair and/or inflation.

⚠ After using the repair kit, the vehicle must however be considered to be in an emergency situation: drive with the utmost care (maximum permissible speed 80 km/h).

The kit is to be used to temporarily repair only one tyre punctured by small-sized objects: the kit may be useless in the case of large punctures or tearing.

⚠ Keep the kit in its box and out of children's reach. Do not inhale or swallow the fluid contained in the cartridge

and avoid contact with the skin and eyes.

The repaired tyre must be replaced as soon as possible and the workshop personnel must be informed that the tyre was treated with tyre repair fluid.

The sealant contained in the cartridge in the tyre repair kit may damage the sensor fitted inside the wheel rim on vehicles equipped with the tyre pressure monitoring system. In these cases, always have the sensor replaced by an authorised **FERRARI SERVICE CENTRE**.

■ No kit is provided for the spare wheel.

In the event of a tyre puncture, proceed as follows.

- Open the box and take out the compressor. Remove the electrical cable with the connector **F** for the power socket.
- Insert the connector **F** into the power socket, on the central tunnel.

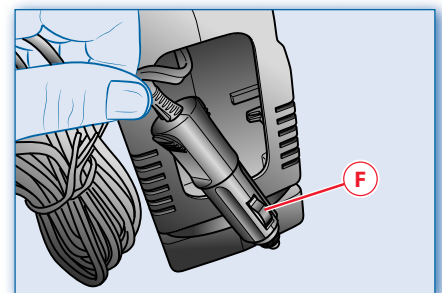

4 - In an emergency

- Unscrew the valve cap of the punctured tyre and screw the union **G** for the transparent tube onto the valve.

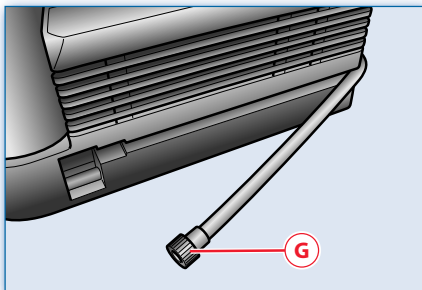

- Turn the ignition key to **II** so that the socket is powered and activate the compressor by pressing the switch **D**.

*To inflate/repair the tyre successfully, the lever terminal part **H** must be fitted into the relevant union **J**.*

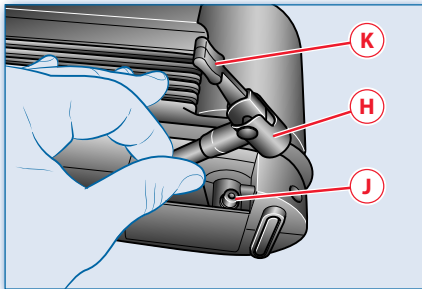

- Stop the compressor when the pressure indicated on the pressure gauge **C** reaches the specified pressure for that tyre (see page 12).
- Remove the union **G** and screw the cap back onto the valve.

We recommend that you check the tyre pressure on the gauge when the compressor is off, in order to have a more accurate reading. Do not activate the compressor for more than 20 minutes: risk of overheating!

The compressor has been designed for inflation of one tyre only; do not use it to inflate mattresses, rubber boats etc.

The kit can also be used only to inflate a tyre using the lever terminal **H**.

- Remove the terminal **H** from the union **J** on the cartridge and insert it in the wheel valve.
- Lower the lever **K** and start the compressor.
- Inflate to the specified pressure (see page 12).

Replacing the puncture repair fluid cartridge

- Remove the terminal **H** from the union **J** on the cartridge and remove the union **G** for the transparent tube from the compressor.
- Turn the cartridge **A** anticlockwise and lift it slipping it off the base. replace it with an original spare part.

- Insert the new cartridge **A** into the base and push it until hearing its fitting click into place in the base.
- Turn it clockwise until it fits snugly into place.
- Place the union **G** into its seat and fit the lever terminal **H** onto the union **J** of the cartridge.

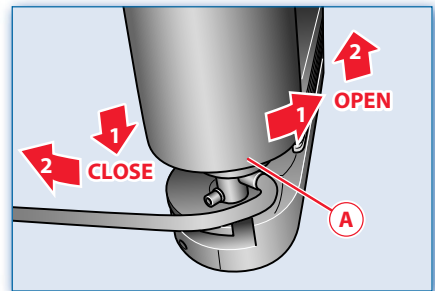

Useful accessories

As well as the tools supplied with the vehicle, the hazard warning triangle and fluorescent safety jacket should always be kept on board in order to signal hazardous situations in compliance with regulations.

Replacing the wheels

! If one or more wheels need to be replaced, proceed as follows:

- Replace the stud bolts with damaged thread or cone.
- Carefully clean the stud bolts before fitting.
- Absolutely do not lubricate the contact surfaces between the stud bolt and the wheel rim and between the rim and the brake disk.

In order not to remove the anti-lock treatment, do not clean the wheel rim cones with solvents or aggressive products.

Spare wheel (optional)

On request, the vehicle can be equipped with a kit containing:

- Spare wheel **A** with smaller tyre. The plate **B** on the spare wheel rim indicates the maximum permitted speed of 80 km/h (50 mph).
- Additional toolkit **C** containing: jack and wrench to fasten the wheel stud bolts.

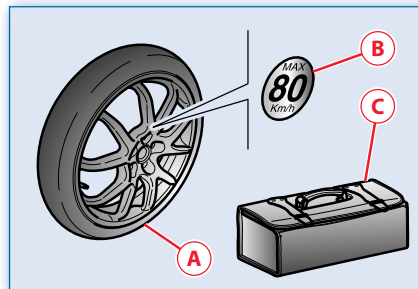
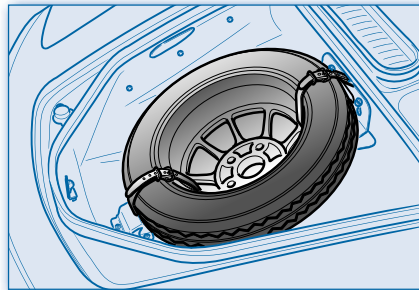

Warning

- Always keep the spare wheel in perfect working order, periodically checking that the inflation pressure is 4.2 bar (62 psi).
- It must only be used for short trips, in emergencies.
- When the spare wheel is fitted, never exceed the maximum speed of 80 km/h (50 mph) and drive carefully, especially around bends and when overtaking, avoiding accelerating or braking suddenly.
- Do not exceed the approved weight limits.
- Do not fit snow chains on the spare wheel.
- Never fit more than one spare wheel at a time.

Failure to comply with these instructions could lead to loss of control of the vehicle and consequently damage to the vehicle and injuries to the occupants.

On vehicles equipped with tyre pressure monitoring system, turn off the engine when you have a puncture. Start it again only after having fitted the spare wheel in order to prevent that the system interprets the spare wheel as a malfunction.

4 - In an emergency

Replacing a wheel

- Position the vehicle on a flat surface, engage the **1st** gear and lock the rear wheels by engaging the parking brake.
- If necessary, switch on the hazard lights and after having put on the fluorescent safety jacket, position the hazard triangle at the required distance from the vehicle.
- Take the spare wheel and the tools out of the luggage compartment detaching them from the retaining belts.

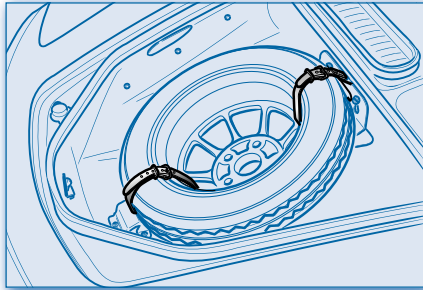

- Loosen the five wheel fastening stud bolts by approximately half a turn using the wrench supplied.

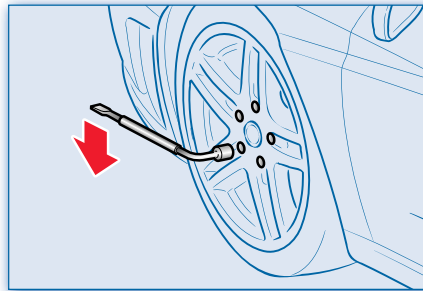

- Place the base of the jack on flat firm ground, in position with one of the jacking points on the underfloor as indicated in the figure by the arrows.

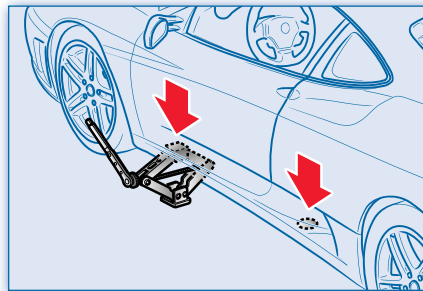

- Carefully jack up the vehicle until the wheel is lifted off the ground.

⚠ If the jack is not positioned correctly, the vehicle could slip off.

The jack supplied must only be used for replacing the wheels.

- Completely unscrew the five stud bolts and remove the wheel.
- Fit the spare wheel and screw the five stud bolts back on.
- Lower the vehicle and remove the jack.
- Fully tighten the stud bolts, alternately going from one stud bolt to the diametrically opposite one in the order shown in the figure.

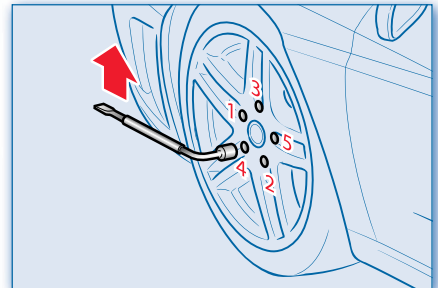

- As soon as possible, secure the stud bolts with the torque wrench, tightening them to a torque of 100 Nm.

F430

The spare wheel is not fitted with a tyre pressure monitoring sensor (see label on spare wheel bag). Hence, after fitting, the wheel is not monitored by the system, however, it complies with International Regulation [ECE R64/01](#). Once fitted, we recommend you go to the nearest **AUTHORISED FERRARI SERVICE CENTRE**.

⚠ After removing the spare wheel support, put the tools and the replaced wheel back into the luggage compartment.

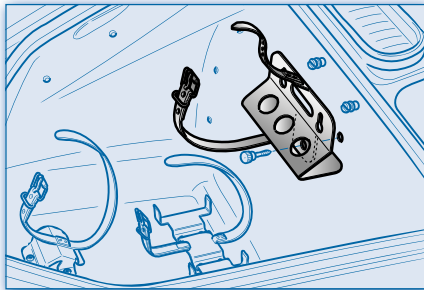

Replacing a bulb

Front lights

- ① Low beam/high beam
- ② Position light
- ③ Front direction indicator
- ④ Side direction indicator

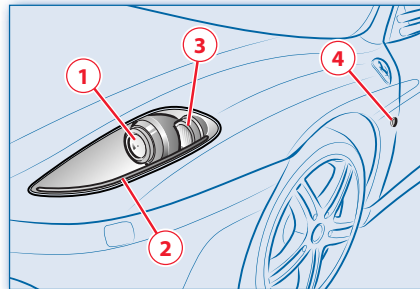

Before replacing a bulb, always disconnect the battery (see [page 101](#)) and check that the corresponding fuse is intact.

When reconnecting the battery, follow the procedure described on [page 101](#).

Low beams/high beams

The low/high beams have high-voltage bi-xenon lamps.

*Avoid any operation with the ignition key in position **II**.*

*For replacement, contact the **FERRARI SERVICE NETWORK**.*

*For headlamp beam aiming, contact the **FERRARI SERVICE NETWORK**.*

Replacing the front direction indicator and position light bulb

To access the headlight bulbs, steer the wheels completely to the inside and remove the inspection lid positioned on the front part of the wheelhouse.

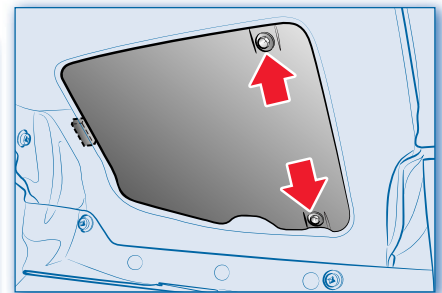

- Disconnect the battery using the battery master switch (see [page 101](#)).
- Turn the bulb holder **A** anticlockwise and remove it from its seat.

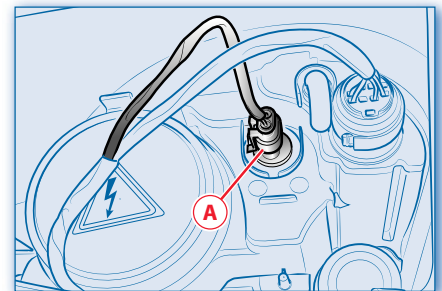

4 - In an emergency

- Remove the bulb **B** by pushing and simultaneously turning it anticlockwise.

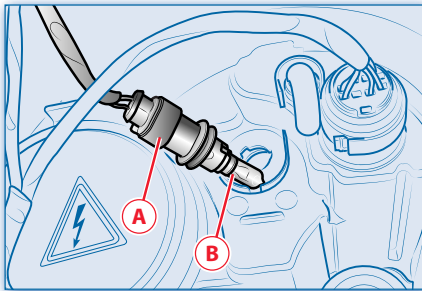

- Fit the new bulb by pushing it into place in the bulb holder and turning it clockwise.
- Reposition the bulb holder in its seat and turn it clockwise until it locks.
- To access the position light bulb remove the protective cap **C**.
- Remove the bulb holder **D** and remove it from its seat.
- Remove the bulb **E** of the position light and replace it.

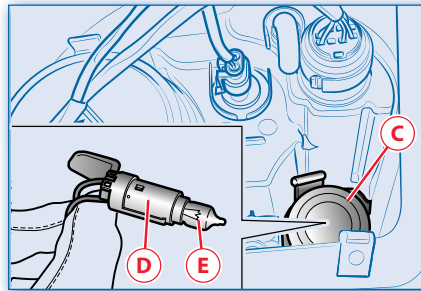

- Reposition the bulb holder in its seat and refit the protective cap.
- Reconnect the battery.

Replacing the side direction indicator bulb

- First remove the indicator transparent cover **A** and then the bulb holder **B**, being careful not to damage the bodywork.
- Remove the bulb **C** removing it from the bulb holder.
- Replace the bulb and refit the bulb holder and then the plastic cover.

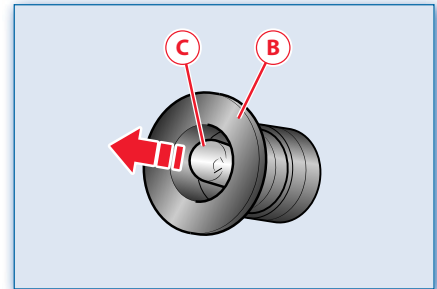
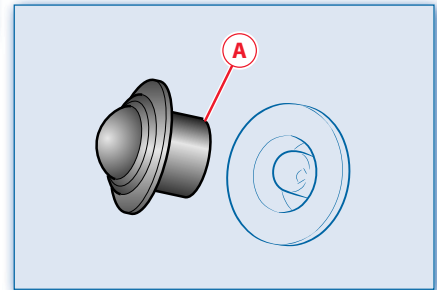

F430

Taillights

- ① Position and stop light
- ② Direction indicator
- ③ Rear fog light
- ④ Reverse light
- ⑤ Number plate light
- ⑥ Auxiliary stop light
- ⑦ Reflector

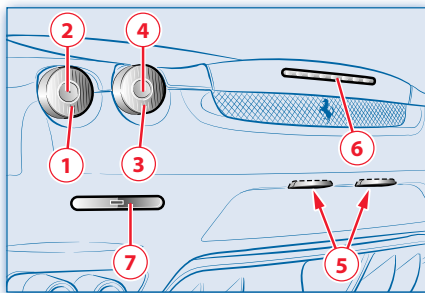

Replacing the tail light bulbs

For replacement, contact the **FERRARI SERVICE NETWORK**.

Replacing the number plate light bulb

- Undo the two retaining screws.
- Remove the bulb holder and replace the bulb.
- Refit the bulb holder and screw down the two retaining screws.

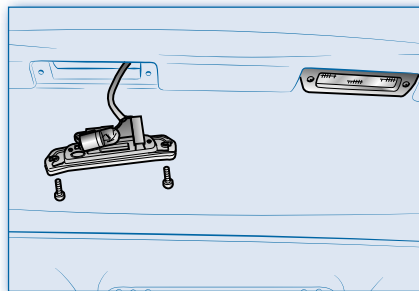

Replacing the auxiliary stop light bulbs

For replacement, contact the **FERRARI SERVICE NETWORK**.

Replacing other light bulbs

Replacing the ceiling light bulb

- Use a screwdriver to gently prise at the point indicated and remove the ceiling light.

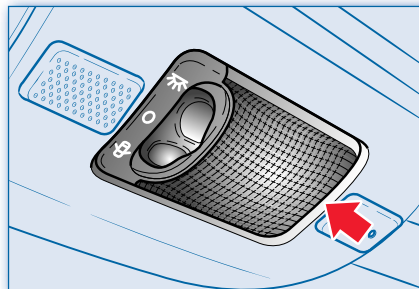

- Manually unclip the bulb holder pressing the two side locking tabs.

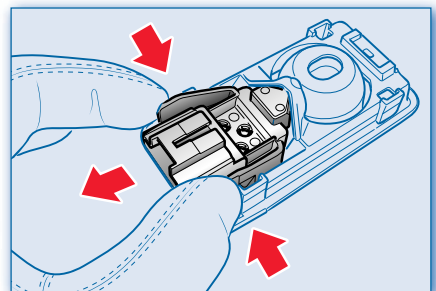

- Remove the bulb from the bulb holder and replace it.

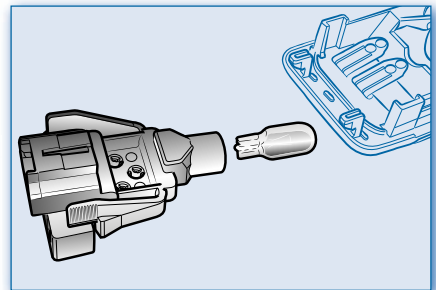

- Refit the ceiling light.

4 - In an emergency

Replacing the glove box light bulb

- Using a screwdriver, gently prise at the point indicated by the arrow and remove the bulb holder.

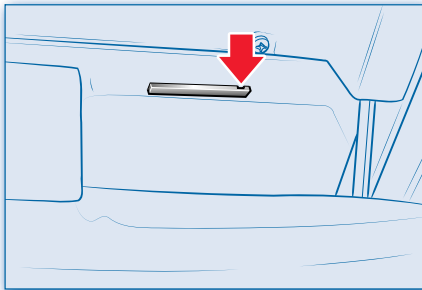

- Replace the bulb and refit the bulb holder.

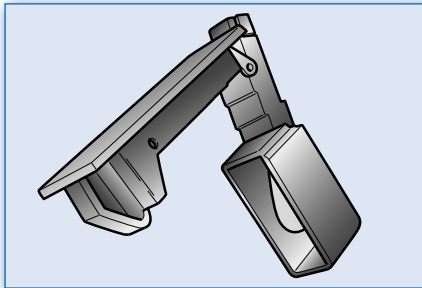

Replacing the "door open" light bulbs

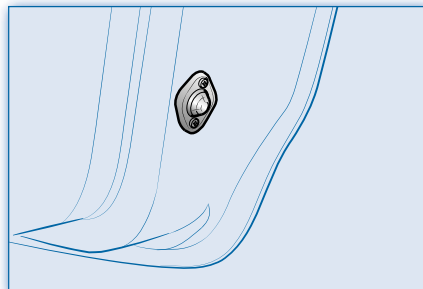

- Undo the two fastening screws.
- Remove the bulb holder, detach the transparent cover and replace the bulb.
- Reassemble the bulb holder and refit it screwing down the two retaining screws.

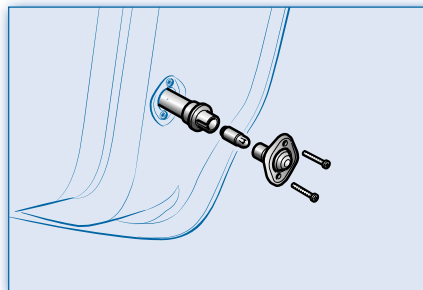

Replacing the luggage compartment light bulb

- Using a screwdriver, gently prise at the point indicated by the arrow and remove the bulb holder.

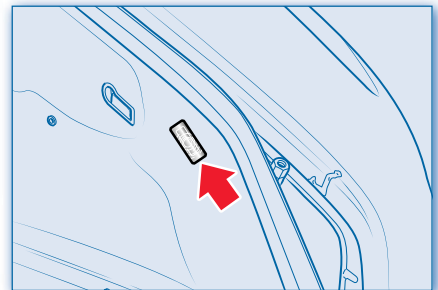

- Replace the bulb and refit the bulb holder.

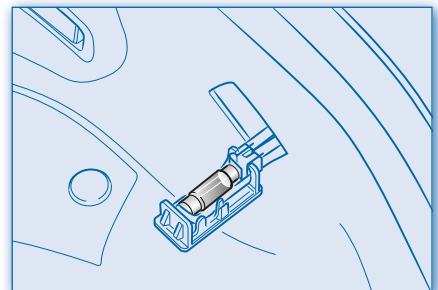

F430

Bulbs

(12 V, except for high beam/low beam)

Low beams/high beams	gas-discharge	Das
Front position lights	incandescent	6 W (H6W)
Front direction indicator lights	incandescent	21W
Side direction indicator lights	incandescent	4W (T4W)
Rear position and stop lights	incandescent	21/5W (P21/5W)
Rear direction indicator/reverse lights	incandescent	6W (H6W)
Rear fog lights	incandescent	21W
Number plate lights	incandescent	5W (R5W)
Central ceiling light	incandescent	10W
Spot light	incandescent	6W
Dashboard glove compartment light	incandescent	5W (W5W)
Door open lights	incandescent	3W
Luggage compartment light	incandescent	5W (W5W)

Replacing a fuse

When an electrical device is not working, check that the corresponding fuse is intact.

A Fuse intact.

B Fuse blown.

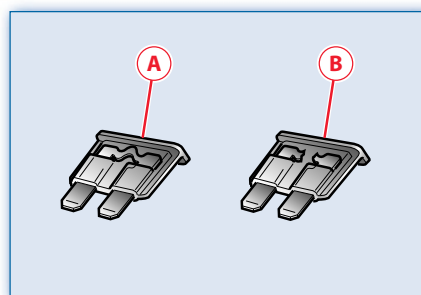

If the fault is repeated, contact the **FERRARI SERVICE NETWORK**.

When replacing a fuse, always use fuses of the same amperage (same colour).

Spare fuses are found in the toolkit.

4 - In an emergency

Use the pliers found in the toolkit to remove the fuses.

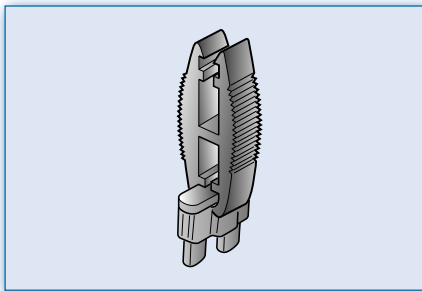

<i>Fuse Colour</i>	<i>Ampere</i>
Yellow ochre	A5
Brown	A7,5
Red	A10
Light blue	A15
Yellow	A20
White	A25
Green	A30
<i>Maxi Fuse Colour</i>	<i>Ampere</i>
Yellow	A20
Green	A30
Orange	A40
Red	A50
Blue	A60

Location of the fuse and relay boxes

- A** Power fuses.
- B** Luggage compartment fuses.
- C** Fuses in passenger compartment, RH side (behind RH seat).
- D** Fuses in passenger compartment, LH side (behind LH seat).
- E** Megafuse (behind the battery).

Symbol legend

- +30 + permanent battery
- +15 + key operated

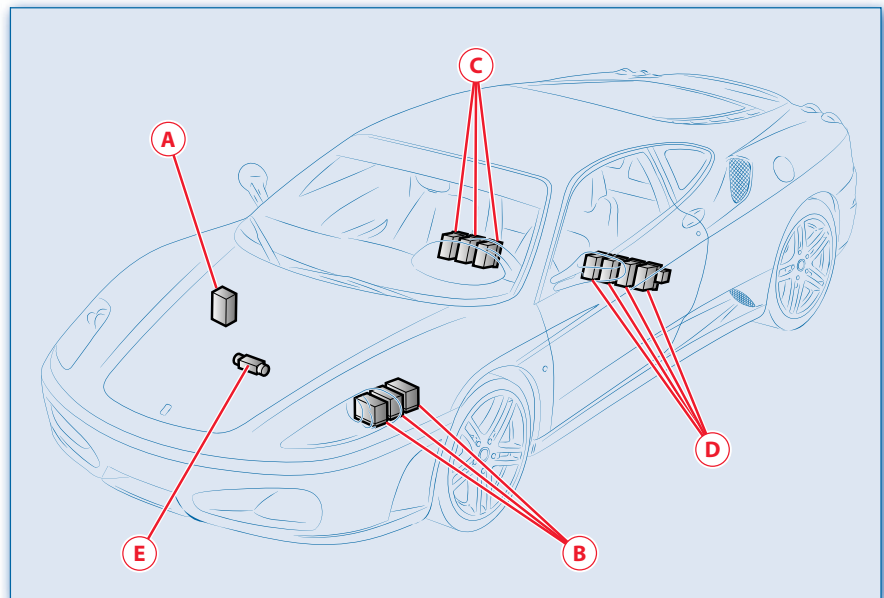

F430

A - Power fuses

Positioned under the passenger footrest, near the battery. To gain access:

- undo the two retaining screws ①, slightly lifting the mat;

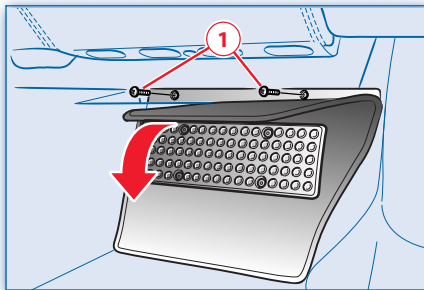

- lower the battery protection panel
- remove the fuse box ② cover.

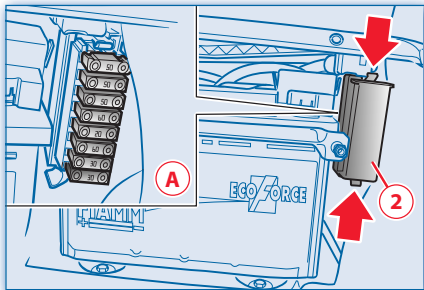

Fuses:

MAXI 1	50A	+30 RH Fan
MAXI 2	50A	+30 LH Fan
MAXI 3	50A	+30 A.C.
MAXI 4	60A	+30 front guard
MAXI 5	20A	+30 alternator sensing
MAXI 6	60A	+30 ABS/ASR/ESP
MAXI 7	30A	RH seat
MAXI 8	30A	LH seat

If a power fuse has blown, contact the FERRARI SERVICE NETWORK to have the system checked.

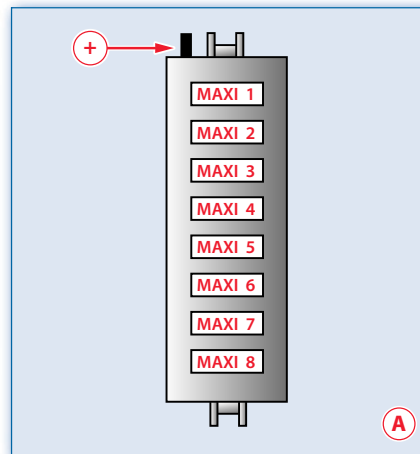

B - Luggage compartment fuses and relays

To access these components, remove the protection panel ① and the box covers ②.

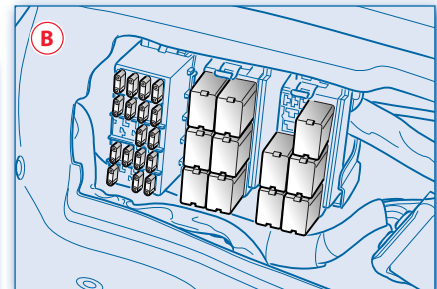
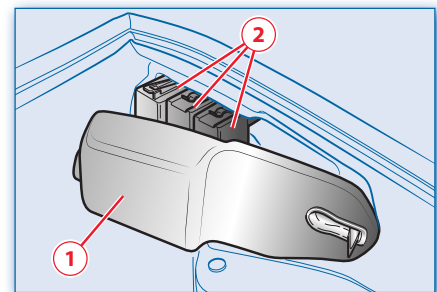

Fuses (MINI):

AF1	15A	High beams
AF2	25A	Low beams
AF3	7,5A	RH high beam
AF4	15A	RH low beam
AF5	7,5A	Number plate lights, switch lights

4 - In an emergency

AF6	15A	Taillights
AF7	7.5A	LH high beam
AF8	15A	LH low beam
AF9	5A	+30 Instrument panel, Bluetooth control unit
AF10	15A	Horns
AF11	—	Position available
AF12	—	Position available
AF13	30A	Headlight washers
AF14	30A	Front lid actuator
AF15	5A	+15 Instrument panel, internal light timing ECU, child safety, passenger airbag deactivation
AF16	5A	RH front and LH rear position lights
AF17	15A	Blinking internal lights, hazard blinking indicators and direction indicators
AF18	15A	Dashboard glove compartment
AF19	—	Position available
AF20	5A	LH front and RH rear position lights

Relays:	
AR1	30A LH Fan
AR2	30A RH Fan
AR3	30A Lid opening actuator
AR4	30A Child safety
AR5	20A High beams
AR6	20A Low beams
AR7	20A Dashboard glove compartment
AR8	— Position available
AR9	20A Position lights
AR10	20A Parking lights
AR11	20A Number plate lights, switch lights
AR12	20A Horns

C - Right-hand side passenger compartment fuses and relays

To access them, remove the protection panel and box covers ①.

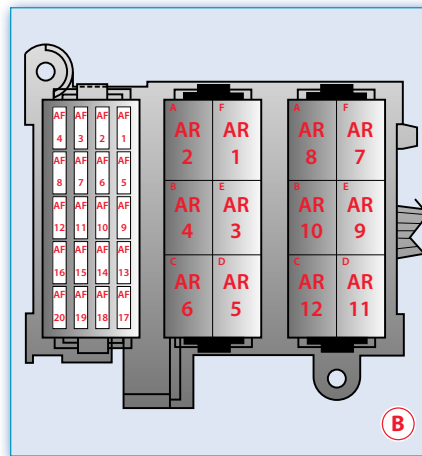
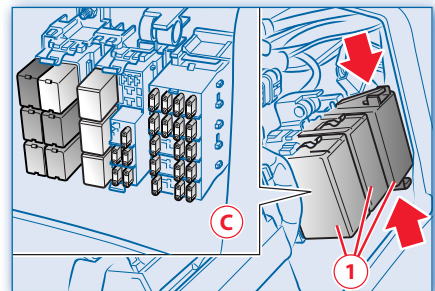
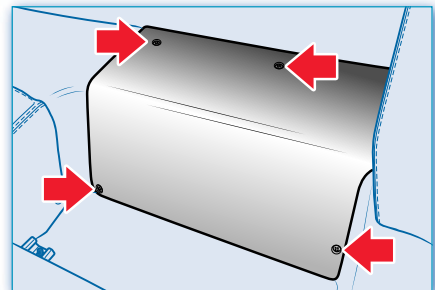

F430

Fuses (MINI):

- PDF1** 10A +15 RH Motronic, Pin 86 on PDR8 and PDR9 relays
- PDF2** 7,5A Rear fog lights
- PDF3** 7,5A External rear view mirror defroster
- PDF4** 15A RH Lambda sensors
- PDF5** 15A Stop lights
- PDF6** 25A +30 Windscreen wiper
- PDF7** 30A Heated rear window
- PDF8** 10A Positive from main RH relay. (PDR10)
- PDF9** 20A +15 Radio, rear view mirror switch, fuel tank flap, direction indicators switch, cigarette lighter, parking sensors
- PDF10** 30A +30 Radio, radio amplifier, parking sensors
- PDF11** — Position available
- PDF12** 15A Air flow meter, exhaust bypass valve, anti-evaporation diagnostic pump, anti-evaporation valve, immobilizer relay, intake manifold valve, A.C. relay
- PDF13** 5A +15 Alarm system, immobilizer
- PDF14** 5A +30 Alarm system, immobilizer
- PDF15** — Position available

- PDF16** 15A RH ignition coils, RH injectors
- PDF17** 15A Windscreen washer/ wiper
- PDF18** 15A +30 key
- PDF19** — Position available
- PDF20** 10A RH Timing variators
- PDF21** 7,5 +30 RH Motronic
- PDF22** — Position available
- PDF23** 30A RH Motronic (main)
- PDF24** 10A +15 ABS - ASR - ESP
- PDF25** 15A +30 Fuel pump relay 1 (PDR8) and fuel pump relay 2 (PDR9)
- PDF26** 10A +87 Tyre pressure monitoring system (TPMS)

Relays:

- PDR1** BOSCH Immobilizer (spec. BOSCH switch)
- PDR2** 30A Key-operated devices
- PDR3** 30A Heated rear window/ rear view mirror defroster
- PDR4** 20A Rear fog lights
- PDR5** 30A +30 Windscreen wiper
- PDR6** 20A +15 Windscreen wiper
- PDR7** 20A +Heated seats
- PDR8** 20A RH fuel pump - Speed 1 (BOSCH)
- PDR9** 20A RH fuel pump. - Speed 2 (BOSCH)
- PDR10** 20A Main for RH Motronic (BOSCH)

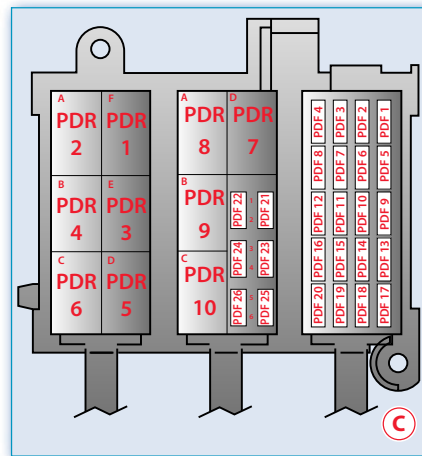

4 - In an emergency

D - Left-hand side passenger compartment fuses and relays

To access them, remove the protection panel and box covers ①.

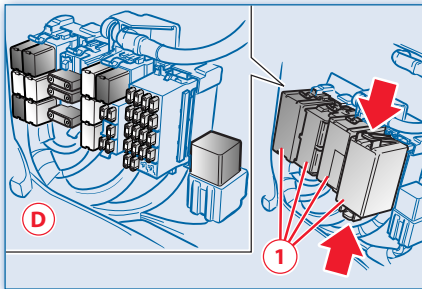
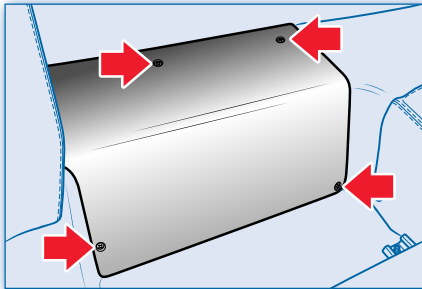

Fuses:

PSF1	10A	+15 LH Motronic, +86 on LH fuel pump relays. (PSR8 and PSR9)
PSF2	20A	F1 ECU
PSF3	30A	+30 RH power window
PSF4	15A	LH Lambda sensor

PSF5	7.5A	+15 shock absorber damping (Skyhook), +15 alternator, +15 electric differential
PSF6	15A	+30 Door locking system
PSF7	30A	+30 LH power window
PSF8	10A	Positive from main LH Motronic relay. (PSR10)
PSF9	10A	+15 Airbag
PSF10	15A	Battery charger
PSF11	10A	+30 Engine control system (OBD), +30 tyre pressure monitoring system (TPMS), +30 electronic differential
PSF12	15A	Air flow meter, exhaust bypass valves, anti-evaporation

		diagnostic pump, anti-evaporation valve
PSF13	10A	+15 Air Conditioning system, +15 recirculation pump
PSF14	30A	Starter motor
PSF15	15A	Ceiling light, door lights, glove compartment lights, parking light control
PSF16	15A	LH ignition coil LH injectors
PSF17	—	Position available
PSF18	—	Position available
PSF19	15A	A.C. compressor
PSF20	10A	LH timing variator
PSF21	7.5A	+30 LH Motronic
PSF22	10A	Reverse light

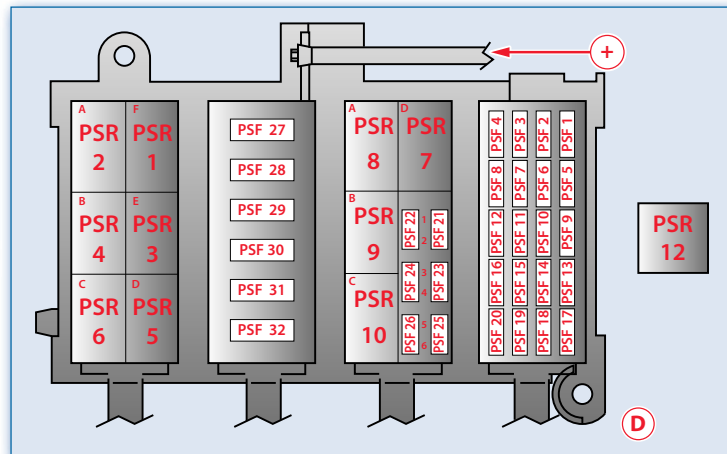

F430

PSF23	30A	LH Motronic. (main)
PSF24	15A	Power socket
PSF25	15A	+30 fuel pump relay 1 (PSR8) and fuel pump relay 2 (PSR9)
PSF26	5A	+15 connected devices relay (excluding ignition)
PSF27	20A	+Heated seats
PSF28	60A	+30 rear LH module guard
PSF29	60A	+30 rear RH module guard
PSF30	—	Position available
PSF31	30A	F1 Pump/E-DIFF
PSF32	—	Position available

Relays:

PSR1	20A	A.C. Compressor
PSR2	20A	Reverse gear switch
PSR3	20A	Key-operated devices
PSR4	20A	Cutout switch for disabling starting with battery charger (normally closed)
PSR5	20A	Connected devices switch (excluding ignition)
PSR6	30A	Starter motor
PSR7	20A	Ignition anti-repeat
PSR8	20A	LH fuel pump - Speed 1 (BOSCH)
PSR9	20A	LH fuel pump. - Speed 2 (BOSCH)
PSR10	20A	Main for LH Motronic (BOSCH)
PSR12	50A	F1 Pump

E - Megafuse

Located behind the battery, on the connection cable between the alternator and the battery positive terminal.

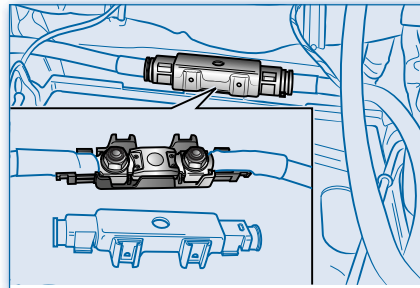

Emergency ignition

Flat battery

Consult the section "Battery" in Chapter 5 "Maintenance" to always keep the battery in perfect working order.

To access the battery, undo the two retaining screws **A** and lower the protection panel.

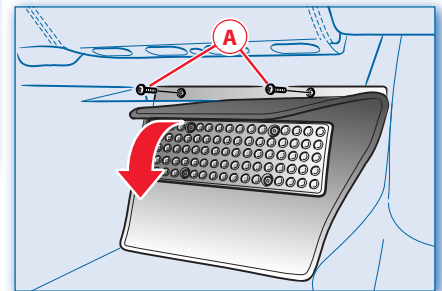

Starting with the auxiliary battery

Use an external 12V battery with the same power or slightly higher than the one provided. A lead acid battery charger of adequate power may be used by qualified persons only.

Use cables with suitable characteristics.

- First connect the terminals of one cable to the positive poles (+) and then the terminals of the other cable to the negative poles (-) of the two batteries.
- Start the engine.
- When the engine has started, first remove

4 - In an emergency

the cable from the negative poles and then from the positive ones.

If the engine does not start after a few attempts, contact the **FERRARI SERVICE NETWORK**.

⚠ Take care not to let the positive cable come into contact with the vehicle or the negative cable. Improper manoeuvres may cause damage to the electrical system.

Push start

⚠ This is to be avoided as far as possible, since it may cause fuel to flow into the catalytic converters and damage them beyond repair.

Towing the vehicle

Tow hook

When towing the vehicle, avoid attaching the tow hook (provided in the toolkit) to coupling points different from those provided.

- Take the tow hook **A** out of the toolkit bag.
- Screw the hook into place in its seat.

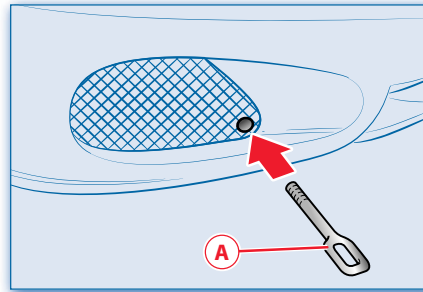

- Position the gearshift lever in neutral (N for vehicles with F1 gearbox).

⚠ The specific driving and road regulations must be followed when the vehicle is being towed.

Do not hook the vehicle onto suspension levers and rims, but only onto the tow hook properly fitted in its seat.

Hold the key in position **II** to allow the lights to work and to prevent locking the steering wheel in the event of steering.

Bear in mind that when the engine is off, the power steering and brake servo are deactivated, hence more force is required to turn the steering wheel and push the brake pedal.

Towing the vehicle with the wheel axle lifted

This may only be done by skilled staff.

Always lift the rear wheel axle only. Ensure that the front wheels are in a straight line and that the steering lock is engaged.

F430

Fuel cut-off inertia switch

The fuel system is fitted with an automatic safety switch which is activated in the event of a collision, cutting off the fuel flow and consequently stopping the engine and preventing the fuel from spreading if the pipes have burst.

 **If you smell fuel after a collision or notice any leaks, do not reset the switch in order to prevent the risk of fire.**

The inertia switch is positioned on the left-hand side of the passenger compartment, in the lower part of the front door pillar and is protected by a metal bracket.

Resetting the system

After checking that there are no fuel leaks:

- Remove the cover and press the button **A** on the switch.

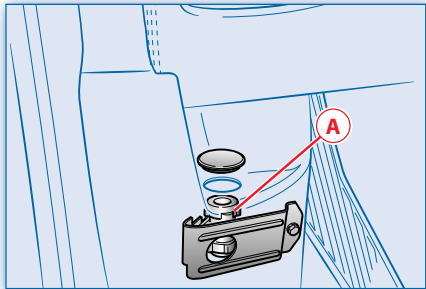

- Turn the key to position **II**, wait a few seconds and start the engine.

- Check once again that there are no fuel leaks.

5 - Maintenance

Warranty booklet _____	98
Maintenance _____	98
Level checks _____	99
Battery _____	101
Windscreen wiper _____	102
Wheels and tyres _____	103
Headlight adjustment _____	104
Cleaning the vehicle _____	104
If the vehicle is laid up for long periods _	105



It is essential to always keep the vehicle in perfect working order to guarantee its original conditions over time and to prevent that malfunctioning due to negligence or non-compliance with the maintenance rules create risks.

All repair work on any component of the safety system must be carried out by the FERRARI SERVICE NETWORK.

Warranty booklet

The vehicle is provided with a “Warranty Booklet and Service Time Schedule” containing the vehicle’s warranty validity conditions.

The Warranty Booklet also contains specific spaces to be filled in by the AUTHORISED FERRARI SERVICE CENTRES, in order to record the periodic service and maintenance carried out according to the Service Time Schedule.

Maintenance

At each indicated period, the FERRARI SERVICE CENTRES must carry out all the tuning operations and relevant checks indicated in the “Warranty Booklet and Service Time Schedule”.

It is however advisable to immediately report to our Service Centres any small fault which may occur during use of the vehicle (e.g. small leaks of essential fluids) and not wait until the next service is due to correct the problem.

It is also required to have the periodic service done at least once a year, even if the specified mileage has not been reached (see “Yearly Maintenance Service” indicated in the “Warranty Booklet and Service Time Schedule”).

Using the Service Time Schedule

The schedule contained in the “Warranty Booklet and Service Time Schedule” also lists, in addition to the specified intervals for the operations indicated, the checks to be carried out annually on the vehicle.

If the vehicle is used in particular conditions (e.g. dusty roads, very high temperatures, heavy-duty use, etc.) some operations need to be carried out more frequently (e.g. air filter replacement, etc.).

For the quality of oils to use, see the table of “Recommended lubricants and fluids” table on [page 14](#).

Level checks

General notes

The level checks must be carried out at the intervals indicated in the "Service Time Schedule" or in any case before starting a long journey.

- Open the engine compartment lid (see page 60).

Use only lubricants and/or fluids recommended by FERRARI (see "Recommended lubricants and fluids" on page 14).

Checking the engine oil level

⚠ The level check must be carried out with the engine warm (oil temperature $>70^{\circ}\text{C}$ / 158°F) and the cap resting on the oil separator filler neck.

Proceed as follows:

- With the engine idling, unscrew the filler cap and check that the level is between the **MIN** and **MAX** notches on the dipstick.
- $\text{MAX} - \text{MIN} = 1,5$ litres (0.33 Imp.Gall.)

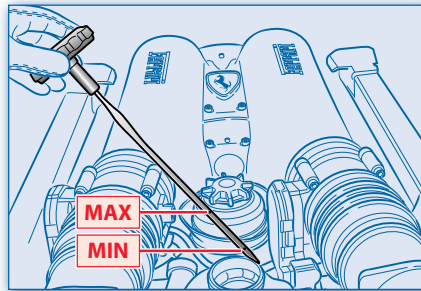

- Top up if necessary with the specified oil taking care not to go over the **MAX** level on the dipstick.
- Screw the cap back on tightly.

⚠ If the oil is under the **MIN** level, top up anyway and have the system checked by a **FERRARI SERVICE CENTRE**.

Checking the gearbox and the F1 gearbox system oil level

It is recommended to have the oil level check carried out at the **FERRARI SERVICE NETWORK** or by skilled staff.

Checking the oil level in the hydraulic steering system

The level check must be carried out with the engine warm after travelling at least 15 km (10 mi.), and with the vehicle parked on flat ground.

- Remove the filler cap and check that the level is between the **MIN** and **MAX** notches on the dipstick.

The oil level check must be carried out with the cap resting on the tank.

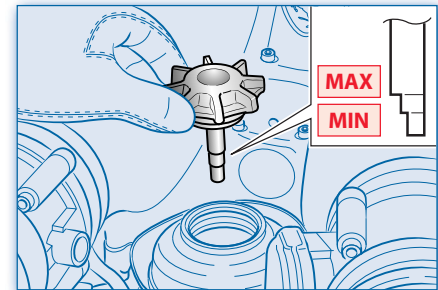

- Top up if necessary with the specified oil up to the **MAX** level.
- Screw the cap back on tightly.

F430

Checking the coolant level

Only perform this procedure with the engine cold. Never remove the cap from the expansion tank when the engine is running and/or warm.

- Remove the cap from the expansion tank in the engine compartment and check that the level is about 40 mm (1.57 in.) from the top of the filler neck.

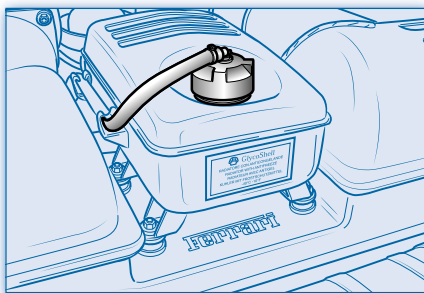

- If the level is low, top it up with the specified fluid.

⚠ If frequent top-ups are required after short trips, have the system checked by the **FERRARI SERVICE NETWORK**.

- Screw the cap back on tightly.

Checking the brake/clutch fluid level

- To access the tank, lift the engine compartment lid (see page 38) and remove the inspection cover.

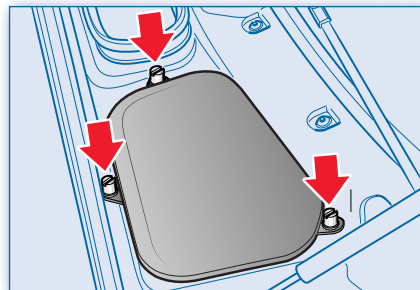

- Check that the fluid in the tank is near the **MAX** level.
- If the level is low, unscrew the filler cap and top up with the specified oil taken from an intact container.

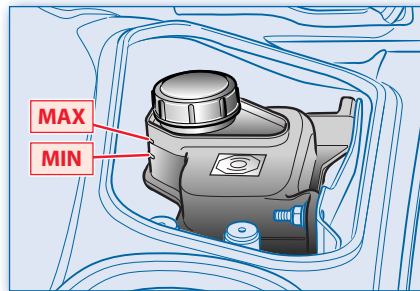

⚠ The oil contained in the brake, clutch and hydraulic steering systems, besides damaging plastic, rubber and painted parts, is highly dangerous if it comes into contact with the eyes or the skin.

In case of contact, wash the affected part thoroughly with running water.

To avoid any risk, always use protective goggles and gloves.

Keep away from children!

Never dispose of used fluid in the environment!

On vehicles with F1 gearbox, the tank supplies the brake system only.

The symbol shown on the adhesive label on the tank indicates that there is synthetic fluid in the system.

⚠ Use of mineral fluids will cause irreparable damage to the rubber gaskets of the system.

Do not use fluids other than those already contained in the system for topping up.

- After topping up, screw the filler cap back on.
- Refit the inspection cover.

Battery

The battery is positioned in the passenger compartment, behind the passenger footrest.

The vehicle is equipped with a sealed lead acid battery that does not require maintenance.

⚠ The battery does not need refilling with distilled water or sulphuric acid.

- To access the battery, undo the two screws **A** under the mat at the top of the passenger footrest panel.

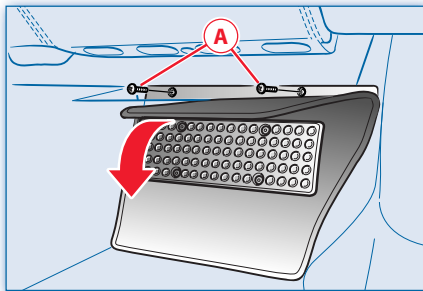

- Remove the panel slipping it off the lower pins.

Periodically check that the terminals and pins are clean and firmly secured.

Visually inspect the outer casing for any cracks.

If the battery runs overcharged, it will wear out quickly.

Have the electrical system of the vehicle checked if the battery tends to discharge easily.

- To remove the battery from the vehicle, disconnect it from the electric system using the battery master switch.
- Detach the terminals from the battery poles.
- Free it from the retaining bracket by undoing the two nuts **B**.
- Detach the breather pipe **C** from the outside of the battery.

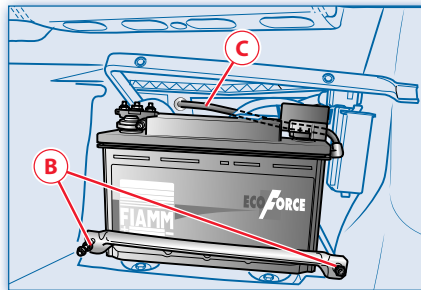

- Remove the battery from the passenger compartment.

⚠ Keep the battery away from sources of heat and do not use naked flames or create sparks near it.

Battery master switch

The earth wire of the battery can be disconnected by means of the specific switch located in the luggage compartment. To disconnect the battery, turn the switch control lever counterclockwise and remove it; it will remain connected to the battery master switch by the dedicated cable.

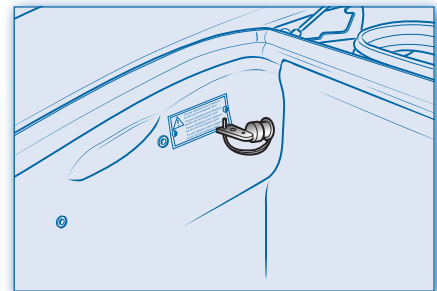

It is advisable to disconnect the battery if the vehicle is not used for long periods of time. Consult the section "If the vehicle is laid up for long periods" in this chapter.

After removing the battery from the vehicle or disconnecting it from the electric system by means of the special switch, when reconnecting and before proceeding with starting the engine wait at least 10 seconds with the ignition key in position **II** to allow the electronic system that controls the motor-driven valves to run the self-learning procedure.

Wait for the vehicle to reach the running speed so that the system can learn all the necessary functions.

To reconnect the battery to the electrical system, insert the control lever in the switch and turn it clockwise until it stops.

The self-learning process for the Motronic ECUs works properly when the intake air temperature is between 5 and 100°C (41 and 212 °F), hence always check that the outside temperature falls within these values before carrying out this operation.

Recharging the battery

⚠ If possible, the battery should be recharged in a well-ventilated area and away from any flammable materials. In certain cases, batteries can produce combustible gases. Do not smoke, use naked flames or create sparks near the battery.

Proceed as follows, using a lead acid battery charger:

- Disconnect the battery using the battery master switch and disconnect the terminals from the battery poles as described earlier.
- Connect the cables of the instrument used to charge the battery to the battery poles.
- When the battery has been recharged, reconnect the terminals to the battery poles, firmly securing the terminal screws, and restore the connection to the electric system by means of the battery master

switch.

⚠ Do not use devices that have to be connected to the cigarette lighter.

Advice for optimal use of the battery

- If the vehicle does less than 1000 km (620 mi.) a month or when it is used in town, the battery charge is sufficient for a maximum of twenty days.
- For longer distances out of town, the charge will be sufficient for about forty days.

Beyond these terms it is advisable to recharge the battery in order to be able to start the vehicle.

If accessories that absorb power other than those provided by FERRARI are fitted on the vehicle (cell phones, navigators, satellite alarm systems etc.), the battery may discharge faster and it will have to be recharged more frequently.

Battery charger outfit (optional)

On request, the vehicle can be equipped with a special connector to connect a battery charger in order to keep the battery charged and for emergency charging.

For instructions on the use of the device see the "SCAGLIETTI BODYWORK PROGRAMME" Owner's manual and the instructions given with the Kit.

Windscreen wiper

In order not to damage the wiper blades, avoid using them when:

- the windscreen is dry
- the blades are stuck to the windscreen due to sub-zero temperatures
- there are traces of snow on the windscreen or the wiper arms
- there are deposits on the windscreen.

The wiper blades must be cleaned periodically and checked for wear.

Replacing the wiper blades

- Turn on the windscreen wiper and stop it (ignition key in position 0) when the blades are in vertical position.

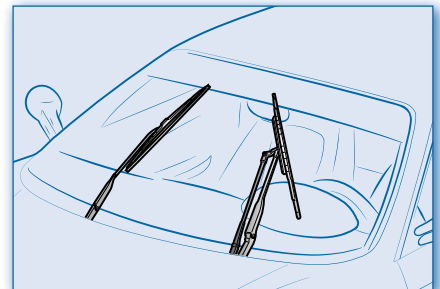

- Lift the arm, remove the blade and replace it checking that it is properly locked on the arm.

Never lift the windscreen wiper arms from the rest position.

Windscreen wiper and washer fluid

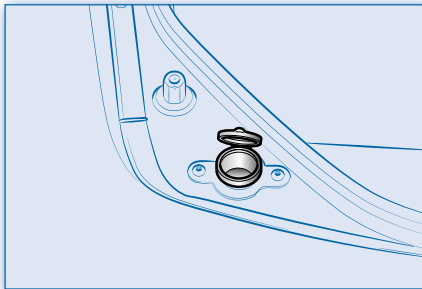

Periodically check that there is fluid in the tank.

The fluid filling manifold for the windscreen wiper and washer can be accessed by lifting the luggage compartment lid.

- Lift the cap and fill the tank with the specified fluid (see the “Recommended lubricants and fluid” table on [page 14](#)) until it can be seen in the filling manifold.
- Close the cap.

Wheels and tyres

To guarantee top performance and endurance and to permit the best tyre adjustment on the rim, it is important to comply with the following instructions for the first 200-300 km (125-190 mi.) of use of new tyres:

- avoid sudden acceleration
- avoid sharp braking and steering
- drive at moderate speed on straight roads and on curves.

How to use the tyres

For safe driving it is of prime importance that the tyres be constantly maintained in good conditions.

The inflation pressure must correspond to the specified values and the tyres should be checked only when they are cold. In fact, the pressure increases as the tyre temperature progressively increases.

Never reduce the pressure if the tyres are hot.

Insufficient tyre pressure can lead to overheating, damage and even destruction of the tyres.

Inflating the tyres to a pressure different from that specified (see table on [page 12](#)) will render the tyre pressure monitoring system inefficient (where fitted).

Violent impact against sidewalks, holes in the road and other obstacles of various types, as well driving on rough roads for

long periods of time may cause damage to the tyres not always visible to the naked eye.

Check the tyres regularly for any signs of damage (e.g. scratches, cuts, cracks, bulges, etc.).

Sharp objects that have penetrated the tyres may have caused damage, which can only be diagnosed by removing the tyre.

Have any damage inspected by an expert as it may considerably reduce tyre life.

Remember that tyres deteriorate with time even if used little or not at all.

Cracks in the tread and sidewalls, possibly accompanied by bulging, are sure signs of ageing.

Have the tyres changed at an AUTHORISED FERRARI SERVICE CENTRE who have the necessary equipment available in order to prevent that a carelessly carried out operation damages the sensor located inside the wheel rim of vehicles equipped with the tyre pressure monitoring system.

Have a specialist assess whether old tyres are suitable for use.

It is recommended to replace the tyres after six years of normal use.

Frequent use in maximum load conditions and high temperatures may accelerate ageing.

In any case, tyres that have been on a vehicle for more than 3 years must be checked by a specialist.

F430

Never fit tyres of uncertain origin.

 The tyres are of the “unidirectional” type and there is an arrow on the side indicating the rolling direction or the outside. When changing the tyres, ensure that the rolling direction corresponds to that indicated in order to maintain optimal performance.

Tyres on the same axle must always be replaced in pairs.

Regularly check the tread (minimum acceptable depth 1.7 mm / 0.067 in.). The thinner the tread, the greater the risk of skidding.

 Drive carefully on wet roads to reduce the risk of aquaplaning.

Tyre pressure monitoring system (optional)

See the description of the system and the warning messages on [page 125](#).

Wheel balancing

The wheels complete with tyres must be balanced at the **FERRARI SERVICE NETWORK** or by skilled staff.

You are advised to use only self-adhesive weights.

Application instructions

Proceed as follows to fit the counterweights:

- Use heptane to thoroughly clean the part of the rim where the counterweight will be applied.
- Remove the backing paper and apply the weight to the wheel, pressing down evenly to ensure perfect adhesion.

Headlight adjustment

To aim the headlights, contact the **FERRARI SERVICE NETWORK**.

Cleaning the vehicle

Cleaning the exterior

Proper care on the part of the owner is essential for a long life of the vehicle.

Below follows a list of the main precautions to be taken.

- Certain parts of the vehicle should not be left wet or dirty for long periods of time, in particular, the passenger and luggage compartment floors must always be kept clean and dry. The drain holes under the doors should be kept unblocked to allow any water to escape.
- The underbody and the lower surfaces of the vehicle should be cleaned regularly, and more frequently (at least once a week) if the vehicle is used on salty or rough roads. It is important to clean thoroughly: cleaning that merely wets encrusted mud without removing it completely can prove damaging.
- The vehicle must be washed regularly with suitable equipment. Do not use very hot water or steam on the paintwork or lower surfaces.

It is advisable to soften any dirt first and then remove it with a jet of water at room temperature.

- Do not wash the car in direct sunlight or when the bodywork is still warm.
- Be careful that the jet of water does not hit the paintwork too hard.

- Wash the car with a sponge and a solution of mild soap and water.
- Rinse the car again with a jet of water and dry it with a piece of chamois leather.

 **When the vehicle has been washed, slightly depress the brake pedal at moderate speed before driving at normal speed so that the brake discs and pads can be cleaned off.**

In order to maintain the shine of the paintwork, polish it once or twice a year with the products recommended by FERRARI.

- Any areas that are cracked or chipped as a result of stones, scratches or parking manoeuvres, etc. must immediately be treated at an **AUTHORISED FERRARI SERVICE CENTRE**.
- Do not park the vehicle in damp and/or unventilated areas for long periods of time.

Cleaning the interior - Cleaning and care of the leather upholstery

Appropriate and regular treatment, at least 3-4 times a year, will ensure that the original quality, natural characteristics and softness of the leather upholstery in your FERRARI is maintained unaltered over time.

With this in mind, specific leather care products are also available (cleaner and cream) perfected and tested by FERRARI. These products can be ordered through the **FERRARI SPARE PARTS SERVICE**

DEPARTMENT both individually and as part of the "Care Kit" which includes the complete range of cleaning products for the vehicle.

For instructions on using the "Care Kit" products, see the "SCAGLIETTI BODYWORK PROGRAMME" Owner's manual and the instructions included in the kit.

Products to be avoided at all costs for cleaning the leather include acidic detergents, turpentine, liquid stain removers, benzene, solvents and domestic cleaning products, as all of these products damage the natural material.

If the vehicle is laid up for long periods

If the vehicle is not used for long periods of time, it is advisable to take certain precautions:

- If possible, park the vehicle on a level surface in a covered and well-ventilated area
- Lock the vehicle in position by engaging a gear and avoid use of the parking brake
- Bring the tyre pressure to 3.0 bar (44 psi) and periodically change the tyre resting point on the ground
- Disconnect the battery from the electric system using the battery master switch as described in the section "Battery" in this chapter.

If you do not wish to disconnect the battery in order to keep certain devices functioning such as: car radio channel memory, alarm system, etc., recharge the battery at least once a month.

If the vehicle is not used for long periods of time with the battery disconnected, the battery must be recharged at least every three months.

- Protect the vehicle with a breathable fabric cover, avoiding materials that prevent the damp on the bodywork from evaporating;

Before using the vehicle again after long periods of inactivity, inflate the tyres to the specified pressure and check the fluid levels of all the systems.

F430

106

6 - Technical Information

Engine	108
Cooling system	110
Ignition-Injection System	111
Fuel system and fuel vapour emission control system	112
Exhaust system	114
Clutch	116
Gearbox	116
Driving and steering	118
Air conditioning/heating system	119
CST system	120
Brake system	120
Suspensions	123
Chassis - Bodywork	127
Electronic Control Units	128



F430

Engine

The vehicle has an aspirated 8-cylinder engine with a displacement of 4.3 litres, which produces a power of 490 HP and a torque of 465 Nm.

The high performance of the engine is achieved through some technical solutions in part derived from racing vehicles:

- variable timing with continuous high-pressure timing variator and dedicated pump on each camshaft;
- chain-driven timing control (one per bank) with hydraulic tensioners;
- four overhead camshafts (two per bank) and four valves per cylinder driven by hydraulic tappets with automatic backlash recovery;
- cylinder heads with combustion chamber of high volumetric and thermodynamic efficiency;
- aluminium alloy and hardened silicone crankcase with wet Nickasil-coated aluminium liners;
- single-piece crankshaft in hardened steel, individually balanced, resting on five main journals with bushings;
- dry sump and oil/water exchanger incorporated in the crankcase, in the centre of the two cylinder banks;
- motor-driven accelerator throttle (drive by wire) and integrated Bosch Motronic ME7 ignition/injection system.

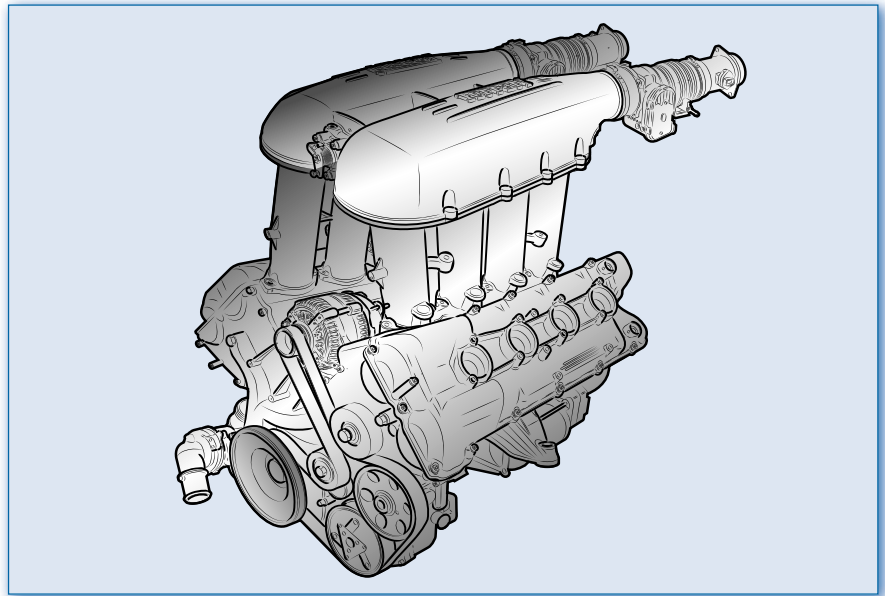

Engine lubrication and gas and oil vapour recirculation

- ① Blow-by system
- ② Gearbox thermistor
- ③ Scavenge and delivery pump
- ④ Suction screen
- ⑤ Pressure regulating valve
- ⑥ Oil filter cartridge
- ⑦ Oil pressure transmitter
- ⑧ Water/oil exchanger
- ⑨ Mesh filter

The lubrication system is of the dry sump type, with fixed gear pumps on the right-hand side of the crankcase. The engine is equipped with three scavenge pumps and a delivery pump. The oil pump unit is coupled to the water pump (see [page 110](#)) and is driven by the crankshaft by means of a chain.

The oil tank with suction chamber is cast in the gearbox and has a separator equipped with cylindrical degassing chamber in the upper part with centrifugal cyclone effect. The separator is fitted with an oil filler plug at the end of the filler neck.

The device for oil gas and vapour recirculation is of the closed circuit type.

In the event of engine malfunctioning with an abnormal rise in pressure, the oil vapours coming from the heads are conveyed to a pipe connected to the blow-by system; from here, a part condenses and

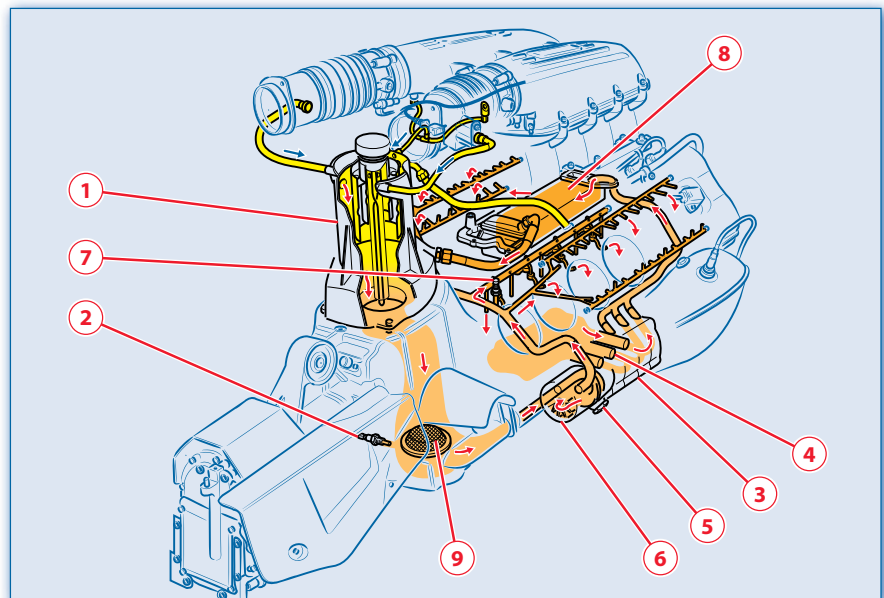

F430

flows into the oil tank underneath. The remaining gases, thanks to the vacuum generated by the engine, are aspirated through the connection pipes and conveyed to the plenum chambers.

A dedicated pipe in the system releases the pressure that accumulates in the oil tank.

Replacing the engine oil and filter

The oil and filter must be replaced at the intervals indicated in the Service Time Schedule at an **AUTHORISED FERRARI SERVICE CENTRE**.

 It is recommended to exclusively use lubricants approved by FERRARI.

Cooling system

- | | |
|--|----------------------------------|
| ① Centrifugal pump with thermostatic valve | ⑥ Underfloor pipes |
| ② Right-hand radiator | ⑦ Twin contact fan on/off switch |
| ③ Left-hand radiator | ⑧ Water temperature sensor |
| ④ Electric fan | ⑨ Oil/water heat exchanger |
| ⑤ Bleeder pipe | ⑩ Expansion tank |

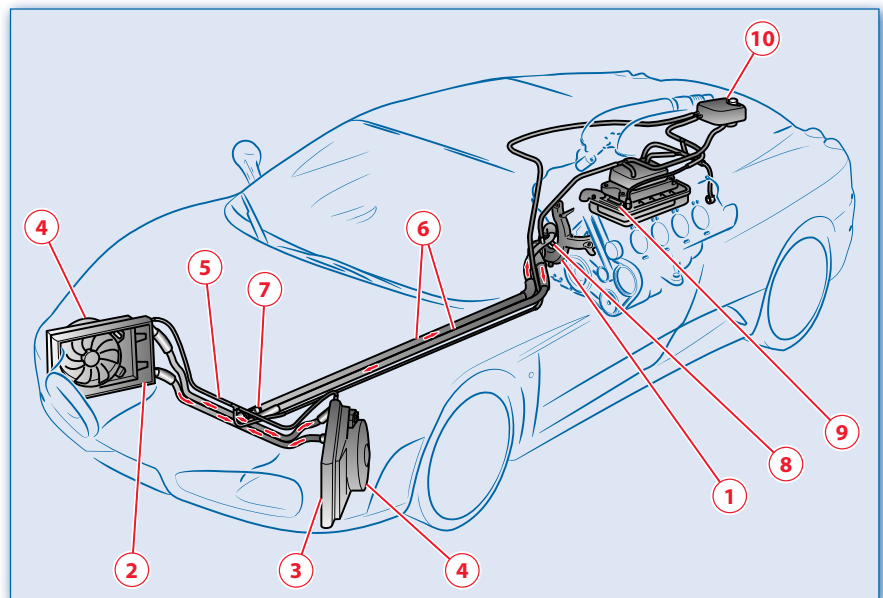

6 - Technical Information

The engine cooling system has a closed-circuit with an expansion tank which compensates the fluid volume and pressure variations due to the engine warming up. A filler neck with plug fitted with a valve calibrated to 0.98 bar (14.4 psi) is installed at the top of the tank.

Coolant circulation is activated by a centrifugal pump (with bypass incorporated in the thermostatic valve) coupled to the oil pump unit (see [page 109](#)) and driven by the crankshaft by means of a chain.

After cooling the engine, the coolant flows to the thermostatic valve which starts opening when the temperature reaches 77-81°C (170.6-177.8 °F), thus sending the coolant to the radiators.

The radiators are positioned on the front of the vehicle in order to improve heat exchange. The right-hand radiator is installed in series with the condenser for the air conditioning system. The hydraulic steering system cooling coil is fixed on the left-hand radiator.

Each radiator is fitted with an electric fan to encourage heat dissipation. The radiators are connected in parallel and are equipped with a duct that is connected to the expansion tank for self-bleeding of the system.

The pump is connected to the radiators by means of pipes running lengthwise across the floor of the vehicle.

A twin contact switch for automatic activation of the electric fan/s is installed on the delivery pipe connecting the two radiators, while the water temperature sensor for the engine ECU is fitted on the water pump upstream of the thermostatic valve.

Replacing the coolant

The coolant has to be replaced at the intervals indicated in the Service Time Schedule at an **AUTHORISED FERRARI SERVICE CENTRE**.

Ignition-Injection system

The system is composed of the following:

- two electronic control units
- two air-flow meters
- engine status sensors (throttle angle, rpm, timing, ignition, etc.)
- engine control and emission actuators (electro-injectors, coils, solenoid valves, etc.)
- peripheral functions connected with engine operation.

The ECU regulates the quantity of fuel to be delivered to the injectors and corrects ignition timing to optimise engine efficiency on the basis of the engine rpm and the quantity of air taken in by the engine.

Each exhaust branch is fitted with a double linear (front) and non-linear (type on-off on the rear) Lambda sensor.

Electronic accelerator (Drive by Wire system)

Drive by Wire is a system that allows the accelerator pedal to work independently from the throttle.

This system is equipped with a potentiometer connected to the accelerator pedal in the place of the connection cable.

This potentiometer informs the engine ECU of the torque request from the driver.

With the Drive by Wire system, it is possible to:

- obtain optimal traction control by means

F430

- of the CST system
- integration with the F1 system in order to optimise gearshifting.
- control warming-up of the power unit.

Fuel system and fuel vapour emission control system

- | | |
|-----------------------------|----------------------------------|
| ① Fuel tank | ⑧ Lower tank connection pipe |
| ② Electric pump with filter | ⑨ Upper tank connection pipe |
| ③ Multi-function valve | ⑩ Canister purge solenoid valves |
| ④ Ventilation valve | ⑪ Active carbon filter |
| ⑤ Separator | ⑫ Air filter |
| ⑥ Injector rail | |
| ⑦ Filler neck | |

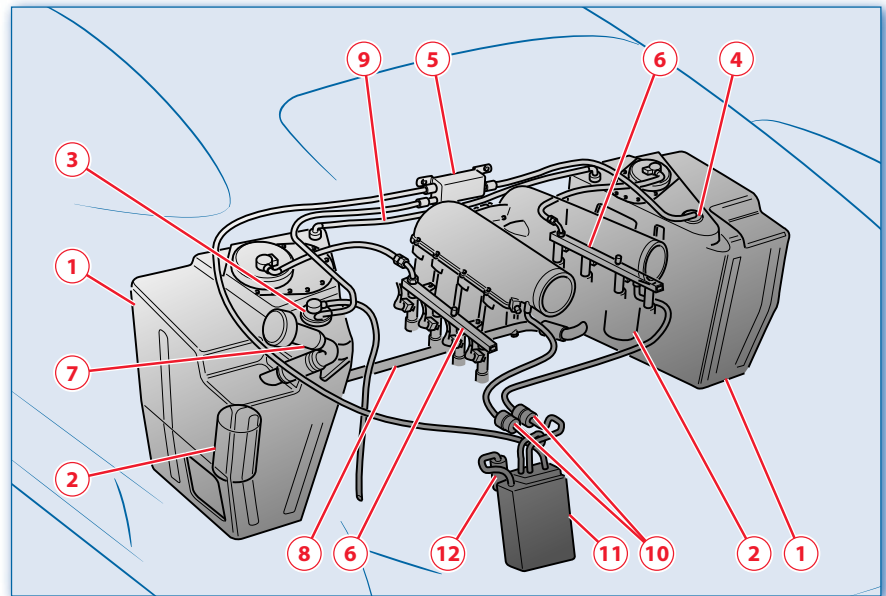

6 - Technical Information

The fuel is aspirated by the two submerged electric pumps in the tank, that are controlled by the ignition-injection ECUs.

The fuel pressure in the delivery line is kept constant by a pressure regulator, incorporated in the pump flange.

The tanks are fitted, on the upper section, with ventilation valves (low vapour bleeding type). These valves are connected to a separator which collects and condenses the fuel vapours.

After passing through the filters inside the pumps, the pressurised fuel is sent to the injector rails on the intake manifolds. This is a "returnless" type system, i.e. no fuel is returned to the tank.

The system is fitted with an automatic safety inertia switch positioned in the passenger compartment, which, in the event of a collision, deactivates the fuel pump relays.

The system is designed to prevent atmospheric pollution caused by fuel system evaporation.

The fuel vapours coming from the tank are conveyed to the active carbon filter where they are absorbed and retained.

With the engine running and depending on the driving conditions, the Motronic ECUs control the canister purge solenoid valves so that the fuel vapours retained by the carbon filter are drawn in by the intake manifolds through the specific lines.

Ambient air is taken into the active carbon

filter through a pipe equipped with a filter that prevents foreign particles from entering the system.

The filler neck is suitably- sized in order to allow inserting only unleaded fuel filler nozzles.

F430

Exhaust system

- ① Exhaust manifold
- ② Front Lambda sensor
- ③ Thermocouple
- ④ Catalytic converter
- ⑤ Rear Lambda sensor
- ⑥ CO sampling seat cap
- ⑦ Silencer
- ⑧ Terminal
- ⑨ Exhaust bypass pneumatic valve
- ⑩ Exhaust bypass solenoid valve
- ⑪ Vacuum tank

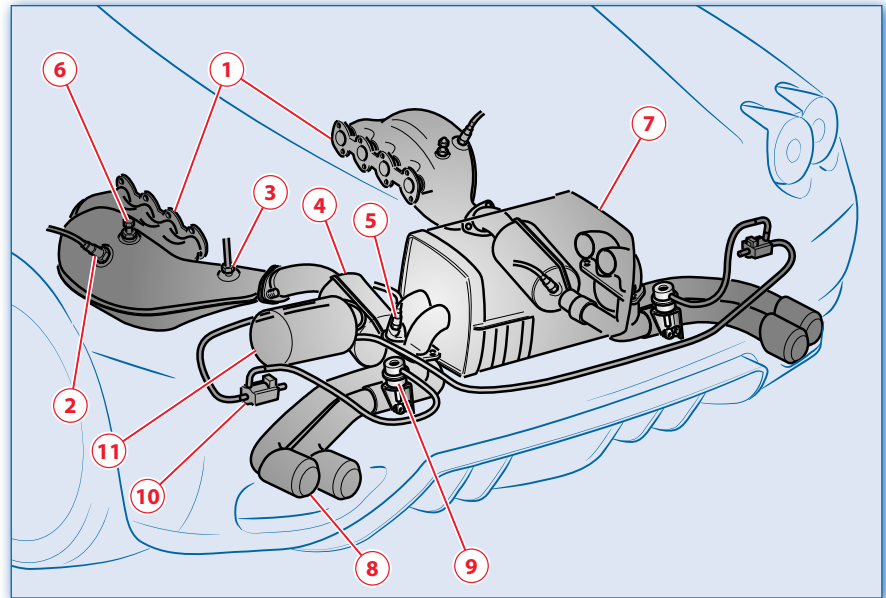

6 - Technical Information

Metallic-type catalytic converters are utilised on this vehicle.

The system is made up of two pre-catalytic converters and two main catalytic converters.

The catalytic converters reduce the emission of HC, CO and NOx into the atmosphere.

Each exhaust manifold contains a pre-catalytic converter which, thanks to its proximity to the gas outlet from the combustion chamber, assures faster heating and greater efficiency in exhaust emission reduction during the phases immediately following engine start-up.

The front Lambda sensor and the thermocouple are secured in the two seats on the manifolds, one at the inlet and one at the outlet of the pre-catalytic converter. The rear Lambda sensor is installed at the outlet of the main catalytic converter.

⚠ To prevent serious damage to the catalytic converters, it is essential that only unleaded fuel be used.

Do not park the car over paper, dry grass or leaves or flammable materials that could catch fire if they come into contact with hot parts of the exhaust system.

Exhaust system overheating alarm devices

If the engine malfunctions with consequent high temperature in the exhaust system, the red warning light on the multi-function display, showing the words **SLOW DOWN** will flash or stay on fixed.

The **SLOW DOWN** symbol activation is controlled by the thermocouple via the Motronic ECU.

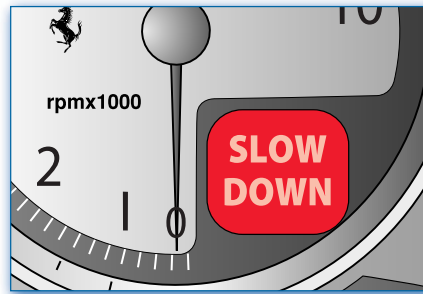

If the warning light flashes,
the catalytic converter temperature is too high.
Slow down immediately and go to a workshop to have the malfunction repaired.

If the warning light remains on,
the temperature in the catalytic converters has reached a dangerous level and could damage them; if continuing to drive, the injection-ignition system ECU will intervene by cutting off the fuel supply to the injectors.

Stop the vehicle and have it towed to a workshop to have the malfunction repaired.

FERRARI is not liable for any damage to property or personal injury arising from failure to comply with the warnings stated above.

F430

Engine malfunction alarm devices

If the warning light “Engine check system failure” flashes or remains on fixed while the engine is running, it indicates that the engine or the emission control system may be malfunctioning.

The electronic system detects and isolates the error, preventing damage to the engine or the production of noxious emissions.

 When the warning light “Engine check system failure” comes on, engine performance may also considerably be reduced.

Drive carefully, avoiding sudden acceleration and high speeds.

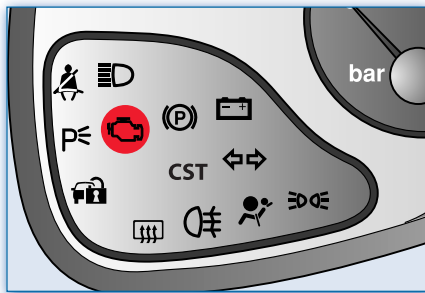

Clutch

The clutch is of the dry double-plate type, with elastic hub and diaphragm spring; its disengagement is controlled by a self-adjusting hydraulic thrust bearing.

Clutch fluid tank

The tank is positioned in the front compartment and is shared with the brake system in the mechanical gearbox version.

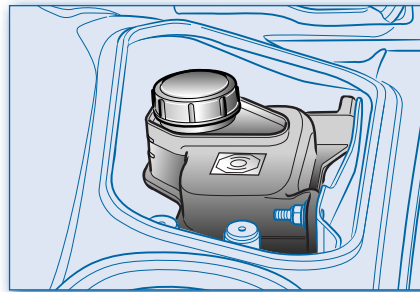

Gearbox

The gearbox has 6 synchronised gears plus reverse gear.

The gears are quick-coupling, with reduced stroke.

The synchronisers are of the double and triple cone type.

The gearbox also contains the bevel gear pair and the electronic differential.

Electronic differential (E-DIFF)

The vehicle is equipped with an electronic differential, working on the rear axle, which continually runs a variable check on the locking between the two axle shafts.

The electronic differential system enhances:

- performance
- directional stability of the vehicle
- active safety even at the limit of grip
- driving comfort and handling.

Operation is based on the analysis and forecast of the vehicle performance in all possible conditions. This is done by continually monitoring the pressure of the clutch actuator on the differential.

The input signals are the dynamic parameters of the vehicle, that the control system translates into a torque difference between the two driving wheels.

6 - Technical Information

On a bend, the electronic differential:

- stabilises the vehicle when the accelerator pedal is released, locking the rear axle
- eliminates typical oversteering conditions, producing slight understeering at the grip limit, locking the differential in proportion to the lateral acceleration and the vehicle speed
- maximises stability and, at the same time, acceleration in a bend, locking the differential in proportion to the lateral acceleration, the speed, the gear engaged and the torque delivered by the engine.

To achieve these results, the electronic differential system interacts with the engine control, F1 gearbox, F1, CST, ABS and shock absorber damping control system.

Alarm devices in the event of electronic differential failure

Any malfunctioning of the electronic differential is shown on the multi-function display of the instrument panel (see [pages 34-35](#)).

Gearbox control

There are two types of gearbox control:

- manually-controlled gearbox with lever, selector, gearbox lever housing and Bowden transmission cables
- electronically-controlled F1 gearbox, which uses an electro-hydraulic system controlled by two levers on either side of the steering wheel. These levers substitute the traditional gearshift lever and clutch pedal.

Compared with the manually-controlled gearbox, the electronically-controlled system offers the following advantages as far as gearbox and clutch are concerned:

- faster upshifting and downshifting
- possibility of shifting to the desired gear without taking your hands off the steering wheel
- greater comfort because of elimination of the clutch pedal
- greater safety, as possible driver errors are prevented
- protection against engine overrunning caused by incorrect gearshifting.

Gearbox and differential lubrication

The gearbox and the differential gearings are lubricated by a volumetric concentric gear pump driven by the auxiliary reverse gear.

Gearbox oil cooling circuit

The gearbox/differential oil temperature is regulated by a water/oil heat exchanger positioned on the engine crankcase, between the banks.

Checking and changing the gearbox/differential oil

The gearbox/differential oil must be checked and changed at the intervals indicated in the Service Time Schedule at an **AUTHORISED FERRARI SERVICE CENTRE**.

F430

Driving and steering

- ① Steering box
- ② Collapsible Cardan transmission
- ③ Steering column with steering angle sensor
- ④ Adjustable steering wheel
- ⑤ Hydraulic steering pump
- ⑥ Oil tank
- ⑦ Steering box delivery pipe
- ⑧ Steering box return pipe
- ⑨ Cooling coil

The vehicle is equipped with electronically-controlled rack-and-pinion type hydraulic steering, which is servo-assisted by a variable-calibration hydraulic circuit.

As the speed increases the aerodynamic load exerted on the vehicle together with the pump calibration allows obtaining a constant steering load with a sensation of mechanical driving, which, if steering sharply, assures perfect accuracy and handling.

The steering column is articulated, height-adjustable and power-absorbing, with permanently-lubricated joints. The sensor that communicates the steering wheel position to the various onboard systems is positioned on the steering column.

The hydraulic steering system is composed of a belt-driven pump which drives the auxiliary parts of the engine. The fluid

flowing from the steering box crosses a coil fitted on the front of the left-hand water radiator which cools the said fluid before it is returned to the tank.

In the event of a system failure, the vehicle can still be steered even if greater force is required to turn the steering wheel. In this case, it is advisable to stop the vehicle and contact an **AUTHORISED FERRARI SERVICE CENTRE**.

When the engine is off or if the vehicle is towed, it is harder to steer.

Main specifications

- Lock-to-lock steering wheel turns: 3
- Steering diameter: 10,8 m (35.4 feet)

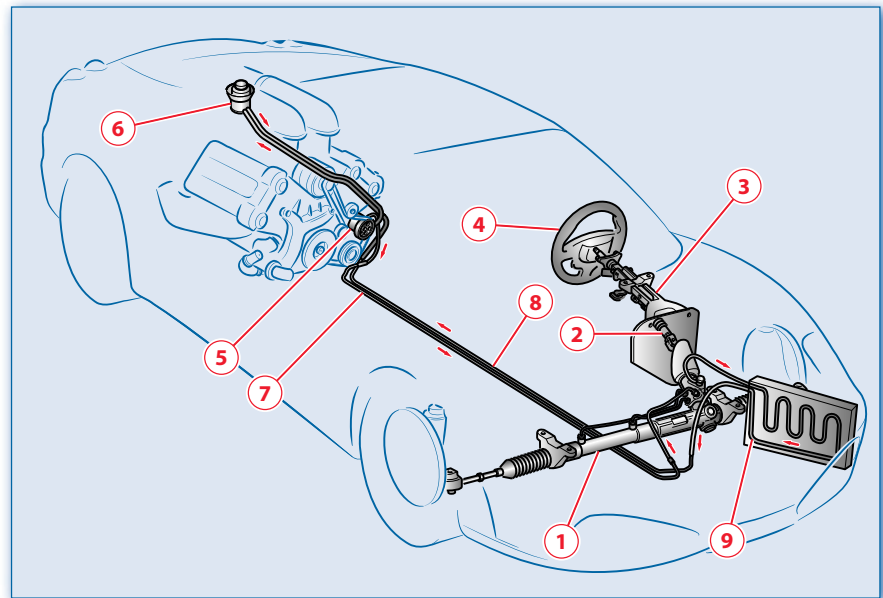

6 - Technical Information

Air conditioning/heating system

- ① Compressor
- ② Condenser
- ③ Dehydrator filter
- ④ Pressure switch
- ⑤ Expansion valve
- ⑥ Heater/evaporator
- ⑦ Proportional valve
- ⑧ Water recirculation pump
- ⑨ Freon draining/refilling unions

The air conditioning and heating system is composed of a heater/evaporator driven by a microprocessor-controlled ECU which, in both automatic and manual mode, keeps the temperature in the passenger compartment constant as the ambient conditions change, regulating the air temperature, flow rate and distribution. It also allows taking in air from the outside or recirculating the air inside the vehicle automatically, regardless of the ambient conditions.

Heater/evaporator

This unit is secured to the partition panel between the passenger compartment and the luggage compartment and it contains the heater and the evaporator in one single assembly. This system allows the user to:

- heat outside or inside air

- cool outside or inside air
- dehumidify and, if desired, heat outside or inside air
- defrost glass surfaces.

Air drawn in from the outside enters the heater/evaporator unit through a pollen filter.

Notes: Replace the pollen filter of the A.C. system at the intervals indicated in the "Service Time Schedule".

The air that comes out of the evaporator flows to a diffuser which distributes it to the vents in the passenger compartment.

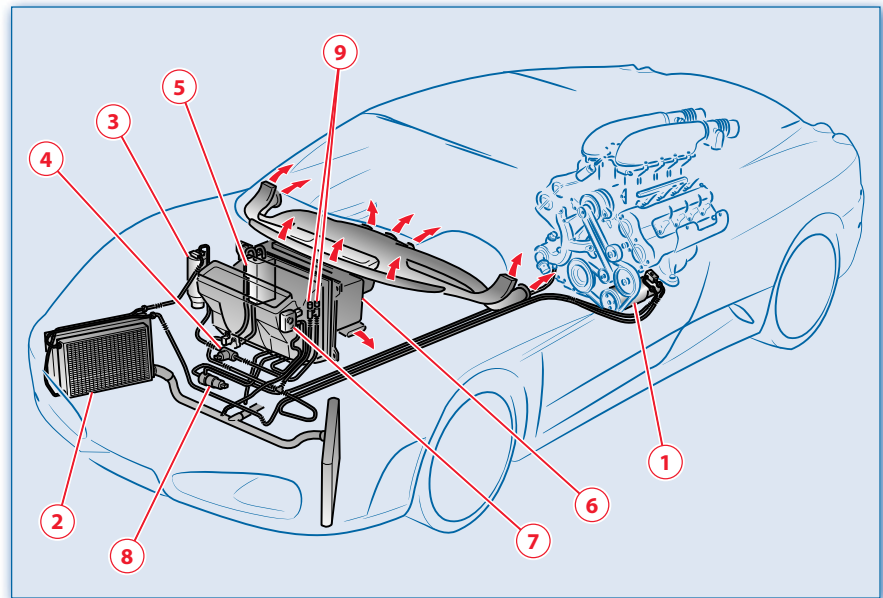

CST system

CST is FERRARI's acronym for Traction and Stability Control. The CST is composed of two main systems:

VDC Vehicle Dynamics Control, through the braking system;

ASR Vehicle Dynamics Control, through the engine torque;

as well as the always active secondary systems such as ABS, EBD, etc.

In order to have optimal control in different driving and grip conditions, four different setting levels have been designed.

Level 1: ensures stability and maximum traction on any type of roadway, both in low-grip ("Low Grip" position) and in very low grip (ICE position) conditions, by means of the engine and brake control.

Level 2: ensures stability and maximum traction only in medium- to high-grip conditions (SPORT position), optimising engine and brake control.

Level 3: enhances the racing features of the vehicle, ensuring (but not in all conditions) a good level of stability (RACE position) by reducing engine control to a minimum and making best use of the brake control.

Level 4: CST deactivated (position ~~CST~~). Stability is not ensured, however, all the other auxiliary systems, such as the ABS and EBD, that are always enabled in the other positions, remain active. (see [page 121](#)).

The driver will easily perceive enhanced driving comfort (engine load limiting and torque feedback), driving will be extremely smooth, without jerks which could be annoying and prevent the driver from fully appreciating the potential of the vehicle. Moreover, the several settings available (depending on the level of grip) allow driving at higher speeds, stability and easy control, in any condition.

Brake system

The hydraulically-controlled braking system is composed of ventilated disc brakes on the four wheels, a "tandem" vacuum brake servo and a hydraulic control unit fitted with solenoid valves and scavenge pump, which intervenes, if the wheels lock, by adjusting the caliper pressure (ABS).

The hydraulic circuits have crossed branching and are independent for the front and rear brakes. If one of the circuits is faulty, emergency braking is always possible if the circuit is efficient.

The vacuum brake servo supplies the hydraulic ECU with brake fluid at the pressure required for system operation.

In the case of ABS activation, the solenoid valves in the hydraulic ECU will intervene with suitable adjusting cycles, in order to prevent the wheels from locking.

Brake fluid tank

Positioned in the front compartment, it is shared with the clutch system in vehicles with mechanical gearbox.

Idle stroke of the brake pedal

The max. idle stroke of the brake pedal should be 8-10 mm (0.315-0.393 in.).

If it becomes excessive, or if one wheel brakes more than the others, or if the control pedal feels springy with reduced braking efficiency, a complete inspection

6 - Technical Information

of the system should be carried out at the **FERRARI SERVICE NETWORK**.

Brake pads

The brake pads are fitted with a wear indicator that is connected to the brake warning light. When this warning light comes on or in any case when braking no longer appears to be regular, the pad thickness and the condition of the braking surfaces must be checked.

The minimum permissible thickness for the pads is 3 mm (thickness of the friction material only).

The brake failure warning light will come on to indicate excessive wear of the brake pads, which must be replaced immediately.

 **If you have the brake pads replaced at an unauthorised workshop, FERRARI is relieved of all responsibility for damage caused to persons or things.**

In order to allow the pads to bed in following replacement, avoid sudden and sharp braking until they have fully adapted (after about 300 km / 186 mi.).

ABS and EBD systems

The vehicle is equipped with ABS (Anti-Blockier System) and EBD (Electronic Brake-Force Distribution) systems which, via the ECU and the ABS sensors, enhance the performance of the braking system.

In the event of an emergency stop or braking on slippery surfaces (where there is snow, ice, etc.), the ABS together with the conventional braking system allow applying the maximum braking force without the wheels locking and consequently losing control of the vehicle.

The system is based on an electronic control unit that processes the signals coming from 4 sensors integrated in the circuits of the 4 wheels.

When a wheel tends to lock, the sensor warns the ECU which, in its turn, signals to the electro-hydraulic unit

to intervene and modulate the pressure on the brake calipers. The driver will perceive a 'pulsing' sensation coming from the brake pedal, which is quite normal.

In the event of a failure, the system will be deactivated, but this will not affect the efficiency of the conventional braking system.

The failure is indicated by the relative warning light on the instrument panel coming on. In this case it is advisable to contact the nearest workshop of the **FERRARI SERVICE NETWORK** who will

immediately identify the fault thanks to the self-diagnostic function with which the system is equipped.

The system performance in terms of active safety must not induce the driver to run unnecessary and unjustified risks.

In any event, always adapt driving conduct to the weather conditions, visibility and the traffic.

The maximum deceleration obtainable is however always dependent on the tyre grip on the road. Obviously, when there is snow or ice on the road, grip is greatly reduced and hence the braking distance is greater even if the ABS system is active.

The vehicles must be fitted with wheel rims, tyres and brake lining of the type and make approved for this model by the Manufacturer.

Although this device greatly contributes to the vehicle's safety, it is still essential to drive with particular care when the road is wet or there is snow or ice.

The vehicle is equipped with an EBD (Electronic Brake-force Distribution) system.

If the warning light comes on when the engine is running, it indicates a malfunction of the EBD system. In this case, sharp braking could lead to the rear wheels locking too early and the vehicle may skid. Driving extremely carefully, immediately go to the nearest workshop of the **FERRARI**

F430

SERVICE NETWORK to have the system checked.

If only the failure warning light comes on when the engine is running, it normally indicates a malfunction of the ABS system only. In this case, the braking system maintains its efficiency, but the anti-locking device cannot be used.

In these conditions the EBD system may also function less efficiently. Also in this case, immediately go to the nearest workshop of the **FERRARI SERVICE NETWORK** to have the system checked, driving in such a way as to avoid sudden braking.

If the brake fluid warning light comes on, immediately stop the vehicle and check the brake fluid level (see [page 100](#)): if the level is below the minimum level, top up with the specified fluid and immediately contact the **FERRARI SERVICE NETWORK** to have the system checked.

In fact, any fluid leaks from the hydraulic system will jeopardize functioning of both the conventional and the ABS braking systems.

The system's performance, in terms of active safety, must not lead the driver to run futile and unjustified risks.

The driving style shall always be suited to weather conditions, range of visibility and road traffic conditions.

The maximum deceleration obtainable is

however always dependent on the tyre grip on the road. Obviously, if there is snow or ice on the road, the grip is greatly reduced and therefore, in these conditions the braking distance is greater, even with the ABS system active.

Suspensions

- ① Shock absorbers
- ② Electronic control unit
- ③ Wheel acceleration sensor
- ④ Vertical acceleration sensor
- ⑤ Failure warning light on instrument panel
- ⑥ Driving mode switch

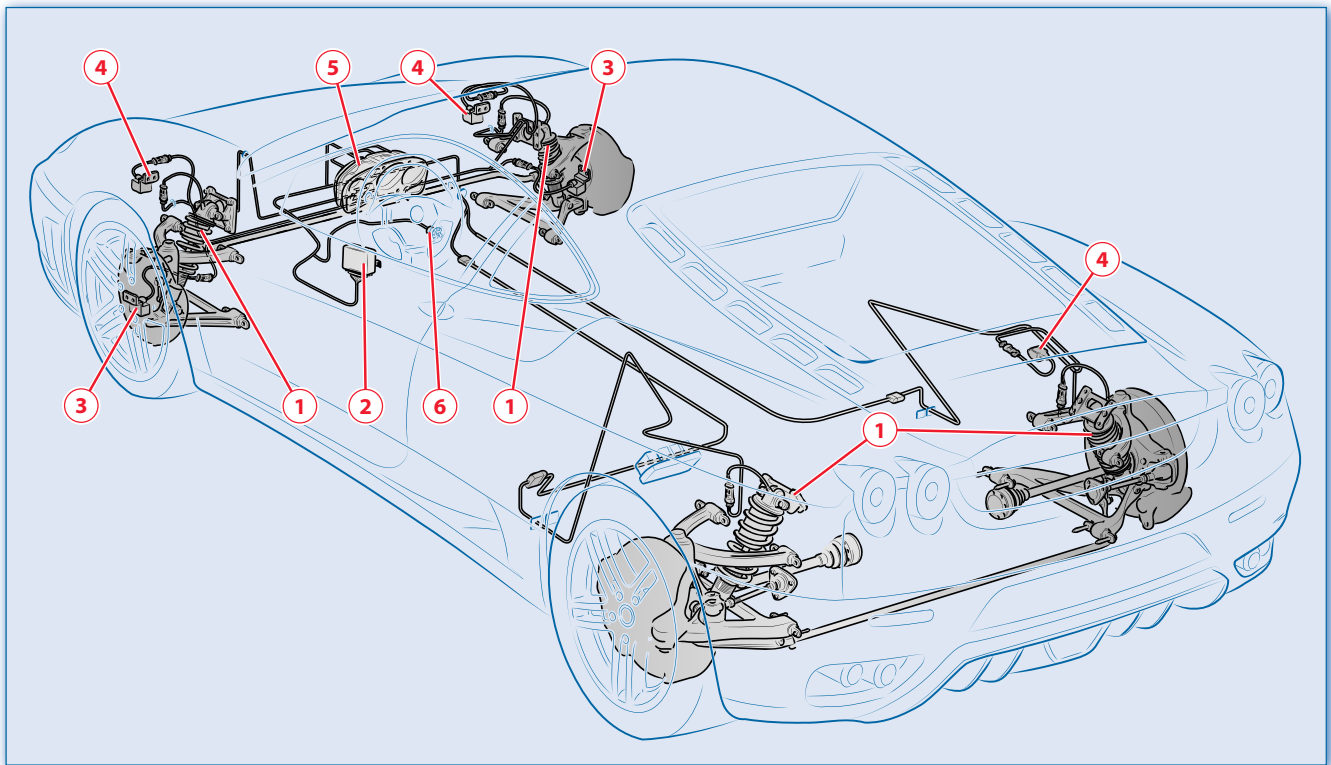

Independent wheels, with upper and lower triangular wishbones.

Double-acting telescopic hydraulic shock absorbers with electronically-controlled calibration variation.

Small kingpin offset to improve braking stability and reduce kickback on the steering wheel to a minimum.

Anti-dive configuration thanks to the upper arm being tilted to reduce front pitching when braking.

Transverse stabiliser bars

A maintenance-free, one-piece double-row ball bearing is fitted on the wheel hub.

The features of the system with which the vehicle is equipped are varied hydraulically and electronically during use depending on the driving and load conditions.

Electronically-controlled active suspensions with continuous damping through the “Skyhook” system.

The suspensions use the “Skyhook” system developed by Mannesmann-Sachs and perfected by FERRARI for continuous automatic damping control via acceleration sensors which record the movements of each wheel and the vehicle body.

Not only does this system always ensure the best compromise between handling and comfort, but it can also slightly enhance one or another aspect by using specific settings. Three different setting levels are available on this vehicle.

Level 1: slightly more flexible setting, optimised to best absorb road unevenness and ensure better grip on wet road surfaces (ICE and “Low grip” position).

Level 2: slightly stiffer setting, optimised for racing-style and high-speed driving (in medium- to high-grip conditions) without reducing comfort dramatically (SPORT position).

Level 3: even stiffer setting, optimised for driving on the race track (RACE and ~~CS1~~ position).

A sensor fitted on the steering column detects the position of the steering wheel (see [page 118](#)).

By processing the sensor output data, the ECU interprets the driving and road conditions and instantly adjusts the shock absorber calibration, ten times faster than any system on the market today.

The system is controlled by an ECU which drives the solenoid valves on each shock absorber on the basis of the signals received from the sensor, modifying damping and hence calibration.

These sensors allow the ECU to calculate the vehicle speed, vertical and lateral acceleration, steering angle and instantaneous pressure in the braking system, and hence to control suspension

damping.

Failure indicator on the multi-function display

Every time a system malfunction is detected, the relevant warning light is activated on the multi-function display on the instrument panel (see [page 34](#)).

If the failure involves a valve, conditions may arise in which one or two of the four shock absorbers may have a fixed calibration (valve locked).

In any case, safe driving of the vehicle is always assured.

The malfunction detected is stored by the ECU.

The system is exclusively designed for connection to the Ferrari SD-3 diagnostic tester, by means of which the system can be diagnosed.

If a malfunctioning occurs while driving causing the relevant warning light to come on, it is advisable to:

- stop the vehicle
- turn the ignition key to position 0;
- restart the engine.

If the malfunction is no longer present (e.g. false contact), the warning light will not come on again and the system will resume normal functioning; otherwise, the system will continue to indicate a malfunction.

In this case, contact the **FERRARI SERVICE NETWORK**.

6 - Technical Information

Tyre pressure monitoring system (optional)

The vehicle can be equipped with a system that measures the tyre pressure through special sensors fitted on the inside of the wheel rims, in correspondence to the inflation valve.

These sensors transmit a signal that is detected by the aerials fitted behind the gravel guards and connected to the ECU. The system can momentarily experience radio-electric interference emitted by devices using similar frequencies.

The ECU processes this information and, via the CAN line, transmits a series of tyre pressure data and system errors, if any, to the on-board instrument panel.

The signal transmitted by the ECU activates some symbols on the multi-function display with two priority levels: a soft warning if the pressure drop with respect to the rated pressure is greater than 0.2 bar, and a hard warning if it is greater than 0.4 bar or if there is a dynamic drop of over 0.2 bar/min. The system is wired so that the aerials, the control unit and the calibration button are connected to the electric system of the vehicle, positioned under the dashboard on the left-hand side of the steering wheel.

Tyre pressure calibration button

To calibrate the system, turn the ignition key to position **II**, press the button located under the dashboard on the left-hand side, holding it down for 4-10 seconds: the **CAL** symbol will appear on the multi-function display.

The system will take a maximum of 20 minutes to complete the calibration procedure with the vehicle in motion.

If the difference in pressure between the wheels on the same axle exceeds 0.4 bar, the system will not calibrate.

If the system detects a pressure drop during calibration, the relevant symbol will appear on the multi-function display (see page 126).

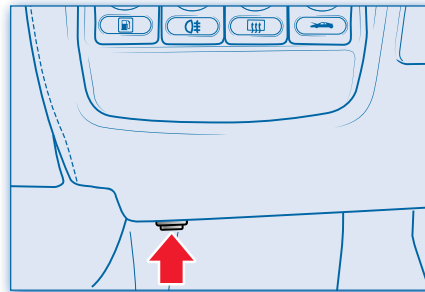

The system must be calibrated using the relevant button on the dashboard after tyre replacement or inflation.

CAUTION The system warns the driver that there is a drop in tyre pressure, however, this does not exempt the driver from periodically checking that the tyres are inflated to the specified pressure (see plate on page 10).

Moreover, the system does not inform the driver of sudden damage to the tyres caused by external agents.

Messages on the multi-function display

The symbol colour defines the priority:

Green: normal conditions of use

Red: when a fault has been detected

Amber: when the driver is requested to check the system.

The following symbols will appear to identify each wheel, the 'solid' square indicating the tyre involved:

- **FL** front left-hand wheel
- **RL** rear left-hand wheel
- **RR** rear right-hand wheel
- **FR** front right-hand wheel

Pressure indication for each tyre



It can be activated by pressing **MODE** button (see page 39) on the multi-function display to view the pressure of each tyre.

If requested when the data is not available, (e.g. during the calibration procedure) the symbols will be shown with -- instead of the value.

Tyre pressure check request without indication of the wheel



Activated for a few seconds after the engine has started. It indicates a drop in pressure with respect to the last value stored.

The system ignores which tyre is involved since it has not yet identified the position. Check the pressure of all the tyres.

Tyre pressure check request



Activated for a few seconds after the engine has started, but unlike before, the system indicates which wheel is signalling the fault.

Check the pressure of the tyre indicated.

Puncture without wheel indication



Activated when a puncture occurs, ignoring the tyre involved since the system is not yet calibrated. It remains on until the ignition key is turned to position 0.

Follow the instructions in the section "Replacing the wheels" on page 82 when only one tyre has a puncture.

Puncture with wheel indication



Activated when a puncture occurs, indicating the tyre involved. It remains on until the ignition key is turned to position 0.

Follow the instructions in the section "Wheels and tyres" on page 82 when only one tyre has a puncture.

System calibration request



Activated for a few seconds after turning the ignition key to position II to signal that the system is not calibrated.

Adjust the tyre pressure and calibrate the system (see page 125).

Confirming the calibration procedure



With the ignition key in position II (without starting the engine) the warning light comes on after pressing the calibration button for about 5 seconds.

The warning light goes off when the engine has started.

During calibration, the tyre condition may be displayed partially (pressure not shown) even if the system has already learned the position from the sensors.

System faulty



The system does not respond or is defective.



Have the system repaired at an AUTHORISED FERRARI SERVICE CENTRE.

System temporarily inactive



Appears when the system is temporarily unable to function. This may occur because of external electromagnetic interference or excessive sensor temperature.

The system automatically resets once the normal conditions are restored.

The message appears in the event of system components replacement.

System inactive



If the system has been deactivated via the diagnostic tester.

After turning the ignition key to position **II**, the warning light remains on for about 50 seconds and then goes off.

Chassis - Bodywork

In order to reduce the weight of the vehicle, the entire bodywork is made of aluminium parts.

Despite the considerable weight reduction, higher stability and resistance can be achieved than with steel sheets.

The aluminium sub-assemblies are less prone to bending and offer excellent resistance to corrosion.

The overall bodywork structure is based on a space-frame chassis.

The body assembly is completed with external sheets (e.g. mudguards, side panels and roof) which, depending on the model, are joined to the space-frame chassis using different joining techniques.

The moving parts secured with screws, such as the luggage compartment lid, the engine compartment lid and the doors, complete the body.

Repair Instructions

In the event of damage to the aluminium parts, the repair always entails replacement of the part. Depending on the extent of the damage, whole assemblies can be replaced or just individual parts. It is not permitted to carry out any straightening work on the aluminium bodies, as can be done with normal steel bodies, given that aluminium cannot easily be restored to its original shape.

In the space-frame section, joints are normally made by welding only.

The body parts may be replaced by means of gluing, riveting, bolting and welding. The aluminium bodies cannot be straightened cold, as is the case with steel sheet bodies, but only at temperatures of approximately 200°C (392 °F).

All body repair work must be carried out exclusively by expert mechanics certified by the **FERRARI TECHNICAL SERVICE DEPARTMENT**.

F430

Electronic Control Units

The figure shows the location of all the ECUs installed on the vehicle.

- ① Motronic (one per bank)
- ② Instrument panel
- ③ Air conditioning/heating system
- ④ Shock absorber calibration adjustment
- ⑤ ABS-ASR
- ⑥ Airbag
- ⑦ Alarm system
- ⑧ Power windows
- ⑨ F1 gearbox (for cars with F1 gearbox)
- ⑩ Electronic differential
- ⑪ Immobilizer
- ⑫ Door locking system
- ⑬ Windscreen wipers
- ⑭ Blinking and hazard lights
- ⑮ Tyre pressure monitoring system (optional)
- ⑯ Bluetooth™ (optional)

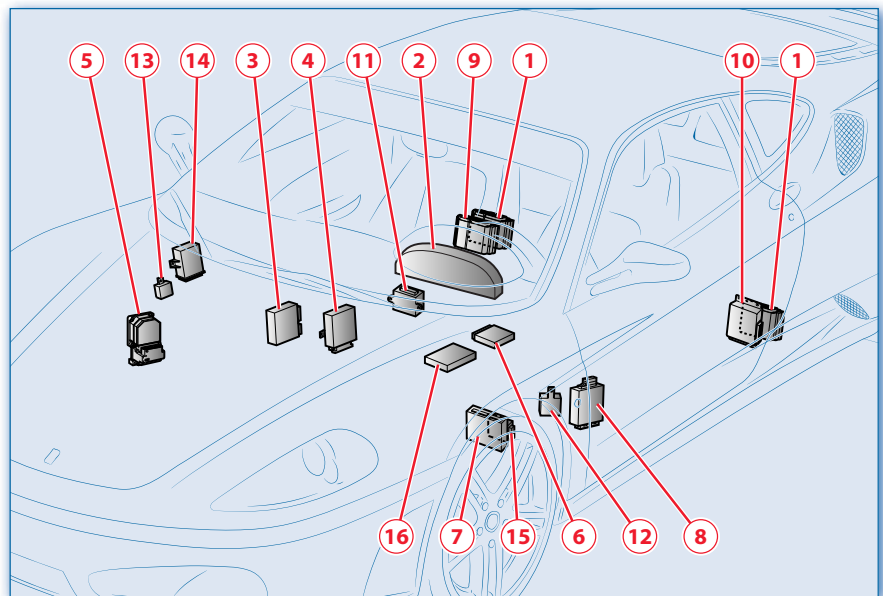

6 - Technical Information

Electronic Control Units

Each system installed on the vehicle is controlled by an electronic control unit (ECU) equipped with microprocessor for high-speed data processing of the data acquired from the sensors and transducers. The features common to all the ECUs are:

Self-diagnostic functions for the relevant system

Each ECU detects functional faults in the components of the system it controls. These faults are recorded as errors and promptly signalled to the user through the warning lights on the instrument panel.

Remote diagnostic functions

The ECUs can be connected to the “SD-3 diagnostic system”.

This is an instrument made available to the **FERRARI SERVICE NETWORK** and allows:

- finding the origin of an error recorded by the ECU and guiding the workshop technician through solving the problem
- acquiring the values of the measurements made during vehicle testing
- running an automatic test cycle of the individual systems
- analysing the data acquired by the ECUs
- deleting the errors detected while driving.

Error management

The errors are recorded in an “erasable” memory at the time of system testing and/or repair and in a non-erasable “historical” memory, thus providing a complete picture of the faults found during the lifetime of the vehicle.

Connection to the CAN line (Controller Area Network)

This is a communication line which allows high-speed data transfer between all the ECUs with high immunity against disturbances.

This allows the ECUs to intelligently “cooperate” in vehicle control.

Diagnostic tester socket

The vehicle is equipped with a universal connector located under the lower dashboard covering, in correspondence to the steering column, to connect the SD-3 diagnostic tester.

By means of this plug-in connection, the tester can interface with all the vehicle’s systems and carry out the diagnosis testing.

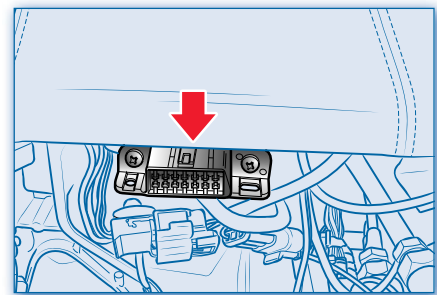

F430

130

7 - Table of contents



F430

12V power socket _____	46	Consumption and CO ₂ emissions _____	11	Exhaust system _____	114
Abbreviations _____	2	Controls on the tunnel _____	43	Exterior lights and direction indicator control lever _____	25
ABS and EBD systems _____	121	Cooling system _____	110	External rear view mirror controls _____	45
Adjusting the air vents _____	63	CST system _____	120	Fuel cut-off inertia switch _____	96
Air conditioning and heating system _____	61	Dashboard controls _____	36	Fuel filler cap flap opening button _____	37
Air conditioning/heating system _____	119	Diagnostic tester socket _____	129	Fuel level gauge _____	31
Airbag _____	55	Dimensions and weights _____	11	Fuel system and fuel vapour emission control system _____	112
Alarm system _____	16	Doors _____	46	Gear display (F1 gearbox) _____	32
Battery charger outfit _____	102	DOWN gearshift lever (F1 gearbox) _____	25	Gearbox and differential lubrication _____	117
Battery master switch _____	101	Driving and steering _____	118	Gearbox control _____	117
Battery _____	101	Driving mode selection switch _____	22	Gearbox oil cooling circuit _____	117
Before a trip _____	66	Driving the vehicle (F1 gearbox) _____	68	Gearbox _____	116
Brake fluid tank _____	120	Driving the vehicle (Mechanical gearbox) _____	72	Hands-free microphone _____	59
Brake pads _____	121	Duplicating the keys _____	17	Hazard lights switch _____	44
Brake system _____	120	Electric system (data) _____	13	Headlight adjustment _____	104
Bulbs _____	88	Electrically adjustable seat _____	48	Heated rear window and exterior rear view mirror defroster button _____	38
Car stereo system _____	42	Electronic accelerator _____	111	Horn control _____	25
Chassis - Bodywork _____	127	Electronic alarm system _____	18	Identification and homologation data _____	8
Checking and changing the gearbox/ differential oil _____	117	Electronic Control Units _____	128	Idle stroke of the brake pedal _____	120
Checking the brake/clutch fluid level _____	100	Electronic differential (E-DIFF) _____	116	Ignition-Injection System _____	111
Checking the coolant level _____	100	Electronic speedometer _____	30	Instruction plates _____	9
Checking the engine oil level _____	99	Electronically-controlled active suspensions with continuous damping through the "Skyhook" system _____	124	Instrument panel _____	29
Checking the gearbox and the F1 gearbox system oil level _____	99	Emergency starting _____	17	Interior rearview mirror _____	49
Checking the oil level in the hydraulic steering system _____	99	Engine _____	108	Internal lights _____	59
Child safety _____	54	Engine compartment lid _____	60	Key switch _____	22
Cleaning the parking sensors _____	78	Engine lubrication and gas and oil vapour recirculation _____	109	Key-operated circuits _____	13
Cleaning the vehicle _____	104	Engine malfunction alarm devices _____	116	Keys _____	16
Clutch fluid tank _____	116	Engine oil pressure gauge _____	30	Laid up for long periods _____	105
Clutch _____	116	Engine oil temperature gauge _____	31	Level checks _____	99
Consulting the manual _____	2	Exhaust system overheating alarm devices _____	115	Load limiting devices _____	53

7 - Table of contents

Location of the fuse and relay boxes _____	89	Replacing the radio control batteries _____	19	Toolkit _____	80
Luggage compartment lid opening button _____	38	Replacing the wheels _____	82	Towing the vehicle _____	95
Main engine specifications _____	10	Requesting new keys _____	19	Transmission ratios _____	10
Maintenance of the seat belts and pretensioners _____	53	Respecting the environment _____	76	Tyre pressure calibration button _____	125
Maintenance _____	98	Rev. Counter _____	30	Tyre pressure monitoring system _____	125
Manual deactivation of the passenger-side airbag _____	56	Rims and tyres (dimensions, type and inflation pressure) _____	12	UP gearshift lever (F1 gearbox) _____	25
Mechanical gearbox lever _____	46	"Run flat" tyres _____	13	Updating _____	2
Mechanically adjustable seat _____	47	Running-in _____	66	Warming up the engine (F1 gearbox) _____	68
Messages on the multi-function display _____	125	Safe driving _____	73	Warming up the engine (Mechanical gearbox) _____	72
Multi-function buttons _____	39	Safety _____	50	Warning lights _____	32
Multi-function display _____	34	Seat belts _____	51	Warranty booklet _____	98
Operation with the engine switched off (F1 gearbox) _____	67	Seat controls _____	47	Water temperature gauge _____	31
Other system functions (F1 gearbox) _____	70	Service _____	2	Wheel balancing _____	104
Parking brake lever _____	45	Shifting (F1 gearbox) _____	69	Wheels and tyres (How to use the tyres) _____	103
Parking lights switch _____	44	Spare parts _____	3	While driving _____	66
Parking _____	72	Spare wheel _____	12	Windscreen wiper and washer control lever _____	27
Parking manoeuvre _____	77	Start button _____	22	Windscreen wiper _____	102
Parking sensor range _____	78	Starting and driving the vehicle (F1 gearbox) _____	67		
Passenger compartment accessories _____	57	Starting and driving the vehicle (Mechanical gearbox) _____	71		
Performance _____	10	Starting the engine (F1 gearbox) _____	68		
Power window control _____	41	Starting the engine (Mechanical gearbox) _____	71		
Pretensioners _____	53	Starting with the auxiliary battery _____	94		
Push start _____	71	Steering wheel adjustment lever _____	28		
Rear fog lights button _____	38	Steering wheel controls _____	21		
Recharging the battery _____	102	Stopping the vehicle (F1 gearbox) _____	70		
Recommended lubricants and fluids _____	14	Sun radiation sensor _____	63		
Replacing a bulb _____	84	Suspensions _____	123		
Replacing a fuse _____	88	Switching off the engine and the system (F1 gearbox) _____	70		
Replacing the coolant _____	111	Switching on the system (F1 gearbox) _____	67		
Replacing the engine oil and filter _____	110				

F430

Specifications and optionals may vary because of specific legal and commercial requirements. Information in this publication is therefore not binding in any way.

FERRARI reserves the right to make any modifications deemed fit, for whatever reason, to the model described in this publication, without obligation of prior notice.

Contact your **FERRARI** Dealer for any further information.

For efficiency and safety's sake, as well as for preserving the car value, it is advisable not to modify the car outfit unless with parts complying with the required type-approval.

COPYRIGHT © Ferrari

Servizio Assistenza Tecnica
Via Abetone Inferiore, 4 - 41053 - Maranello (Modena)

Codice n° 68821000
Catalogo n° 2086/04
3ª Edizione **Settembre '05**
Elaborazioni Tecniche - DECA - Lugo (Ravenna)